

Self checking and easy to use design which can be bolted directly to tank leg, compensates for thermal expansion.

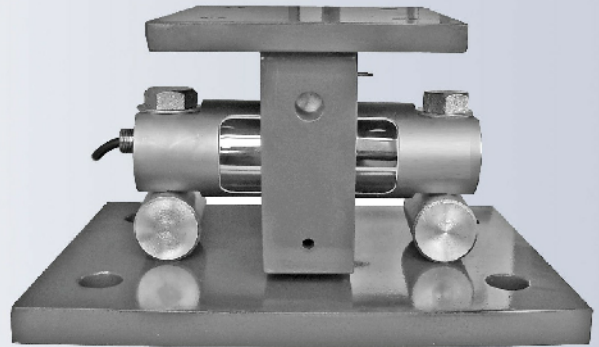

FEATURES

- Capacities 5000 to 150000lb.
- Alloy steel construction.

APPLICATIONS

- Medium to heavy-capacity tank and hopper weighing applications.

OPTIONS

- Stainless steel version.

OUTLINE DIMENSIONS

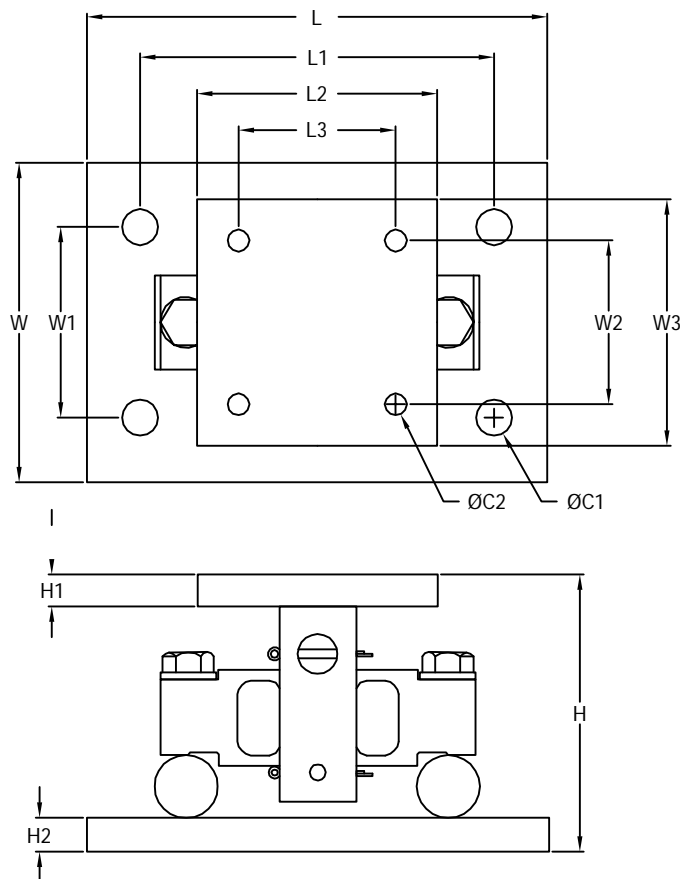

Note :Weigh assembly only. Load cell is not included.

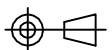

weigh module
2000WM2

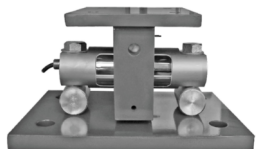

OUTLINE DIMENSIONS

Rated capacity (lb)	C1	C2	H	H1	H2	L	L1	L2	L3	W	W1	W2	W3
5000 - 20000	1.06	0.56	5.27	0.50	0.75	11.00	8.00	5.50	3.00	7.50	4.00	3.00	5.50
30000 - 75000	1.19	0.69	8.42	0.75	1.00	15.00	11.50	7.76	5.13	10.00	6.00	5.13	7.76
100000-150000	1.38	0.81	10.12	1.00	1.25	18.00	14.00	10.00	7.50	12.00	9.00	7.50	10.00

Metric conversion of above table (kg/mm)

Rated capacity (kg)	C1	C2	H	H1	H2	L	L1	L2	L3	W	W1	W2	W3
2268-9071.8	27.0	14.3	133.9	12.7	19.0	279.4	203.2	139.7	76.2	190.5	101.6	76.2	139.7
22679.6	30.2	17.5	213.9	19.0	25.4	381.0	292.1	197.0	130.4	254.0	152.4	130.4	197.0
45359.2- 68038.9	35.0	20.6	257.0	25.4	31.8	457.2	355.6	254.0	190.5	304.8	228.6	190.5	254.0

Dimensions and specifications subject to change without notice



Pioneering Measured Solutions

Group Four Transducers
 22 Deer Park Drive,
 E. Longmeadow, MA 01028
www.groupfourtransducers.com

Phone : **(800) 419 1444**
 Fax : (413) 525 -6182
sales@group-4.com