

Single point load cell for use packaging machines, bench scale and filling machines. Ideal for use in harsh, heavy wash down conditions.

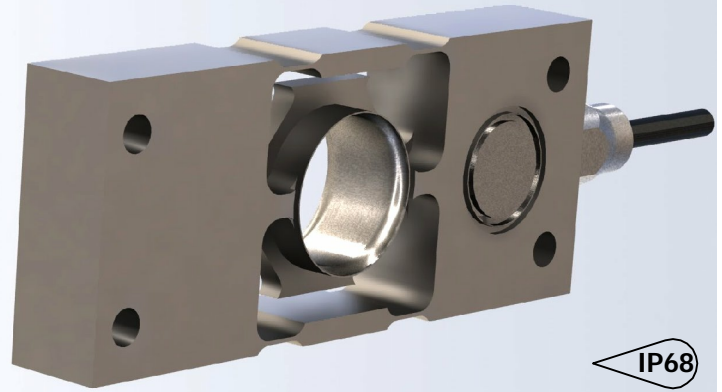

IP68

FEATURES

- Capacity 6kg.
- Stainless steel construction.
- Environmental protection IP68.

APPLICATIONS

- Bench and floor scales, conveyor scales, check weighers, packaging machines and industrial process control.

OPTIONS

- mV/V/ Ω Calibration.

OUTLINE DIMENSIONS

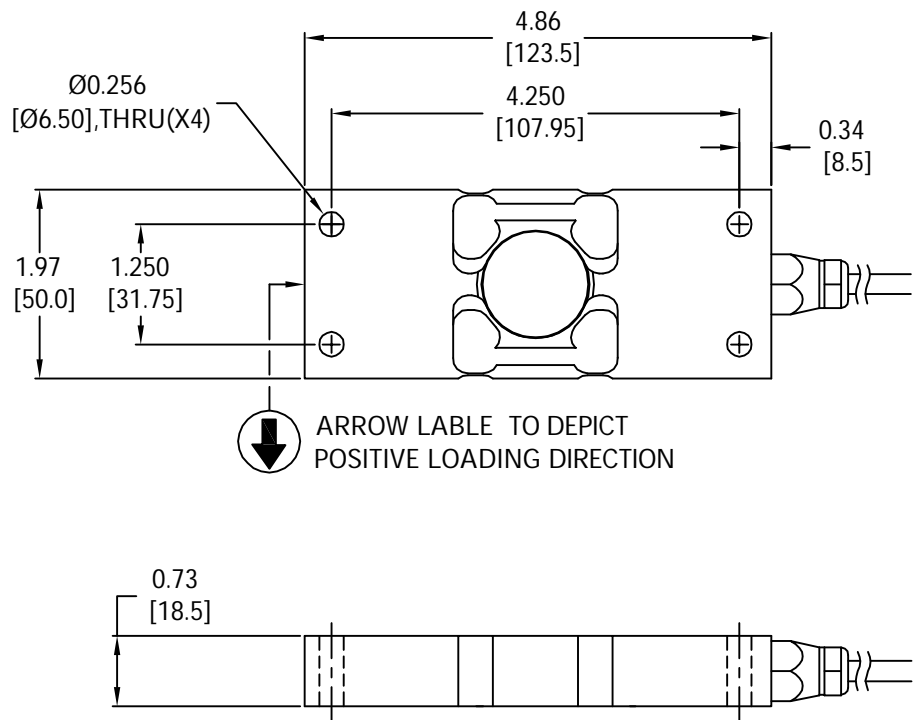

single point

HPS 4067

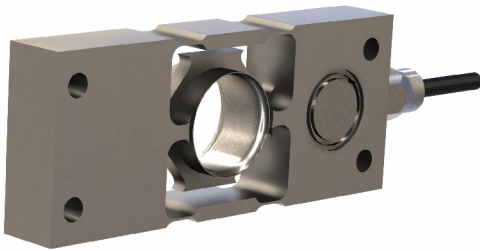

WIRING

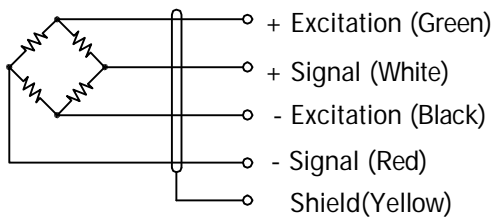

Cable : 24 AWG, 4-Conductor,PU, gray cable with shield.

SPECIFICATIONS

Model	4067		
Capacities	kg	6	
Full scale output(FS)	mV/V	2.0±0.2	
Calibration in mV/V/Ω	%	See options	
Combined error	%FS	≤±0.03	
Non- repeatability	%FS	≤±0.01	
Creep@30min	%FS	≤±0.03	
OCLS			
	Max.offcenter distance	in	6
	OCLS error	mV/V	≤±0.0006@3kg
Zero Balance	%FS	≤±1	
Temperature effect			
	Output	%LOAD/°F	≤±0.0008
	Zero	%FS/°F	≤±0.0015
Temperature range			
	Compensated	°F	+14... +104
	Operating	°F	-40... +175
Terminal resistance			
	Input resistance	Ω	400±50
	Output resistance	Ω	350±10
Excitation voltage	VDC	10... 15	
Insulation resistance@50VDC	MΩ	≥5000	
Safe overload limit	%FS	150	
Ultimate load	%FS	300	
Safe side load	%FS	100	
Cable length	ft	10	
Seal type	IP68		
Element material	Stainless steel		

PART NUMBERS

Capacity(kg)	Part #
6	4067-000-00

Dimensions and specifications subject to change without notice