

The type 5000WM01 is a stainless steel weigh module. This is an innovative, low-profile weigh assembly with built-in uplift restraint and over load protection.

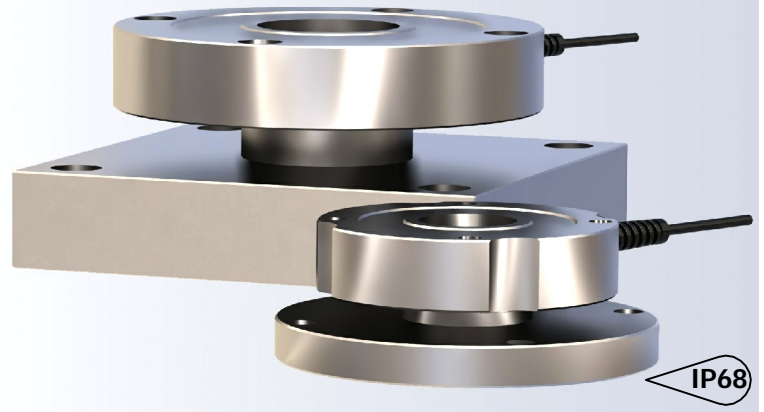

FEATURES

- Capacities from 1klb to 225klb
- Stainless steel construction
- Environmental protection IP68

APPLICATIONS

- Tank, bin, and hopper weighing, silo level indication, bulk bag loading and unloading; and batching, mixing and blending applications

OPTIONS

- Top mounting plates (see p.2).

OUTLINE DIMENSIONS

1klb-125 klb capacities :

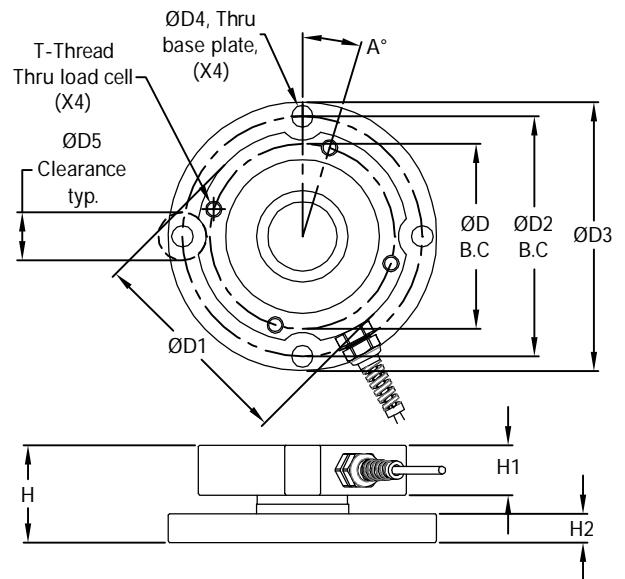

150klb-225 klb capacities :

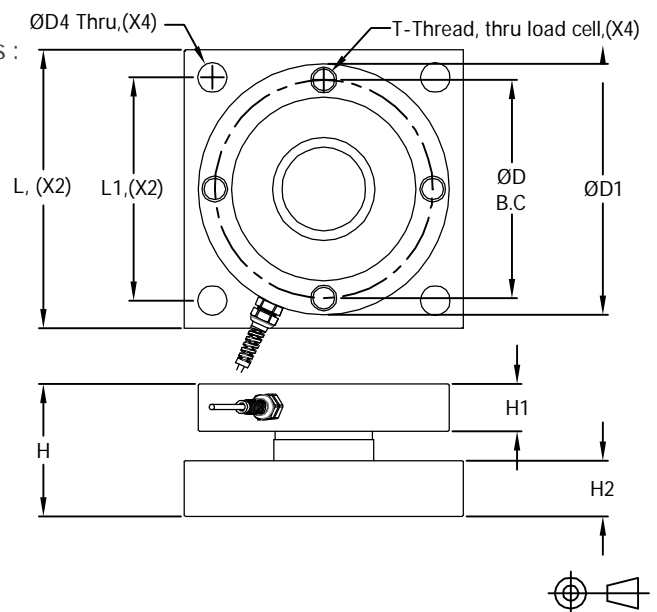

weigh modules

5000WM01

Capacity lbs	H in[mm]	H1 in[mm]	H2 in[mm]	D in[mm]	D1 in[mm]	D2 in[mm]	D3 in[mm]	D4 in[mm]	D5 in[mm]	A	T	L in[mm]	L1 in[mm]
1k-10k	1.37 [34.8]	0.75 [19.1]	0.375 [9.53]	3.000 [76.20]	3.50 [88.9]	3.900 [99.06]	4.50 [114.3]	0.400 [10.16]	0.750 [19.05]	23.00	3/8-16	-	-
20k-50k	2.53 [64.3]	1.30 [33.0]	0.750 [19.05]	4.825 [122.56]	5.50 [139.7]	6.250 [158.75]	7.00 [177.8]	0.563 [14.30]	1.250 [31.75]	17.00	1/2-13	-	-
60k-125k	3.12 [79.2]	1.50 [38.1]	1.000 [25.40]	5.500 [139.70]	6.50 [165.1]	7.000 [177.80]	8.00 [203.2]	0.813 [20.65]	1.750 [44.45]	52.50	3/4-16	-	-
150k-225k	4.75 [120.7]	1.70 [43.2]	2.000 [50.08]	7.825 [198.76]	9.00 [228.6]	-	-	1.060 [26.92]	-	-	1-12	10.00 [254.0]	8.00 [203.2]

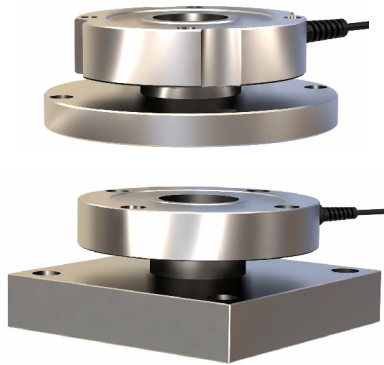

SPECIFICATIONS

Model	5000WM01	
Capacities	See table	
Full scale output(FS)	mV/V	3.0
Non-linearity	%FS	≤±0.20
Non- repeatability	%FS	≤±0.05
Operating temperature range	°C	-12... +43
Bridge resistance	Ω	350
Excitation voltage	V(DC/AC)	10... 15
Insulation resistance@50VDC	MΩ	≥5000
Safe overload limit	%FS	150
Cable length	ft	25
Seal type	IP68	
Element material	Stainless steel	

WIRING

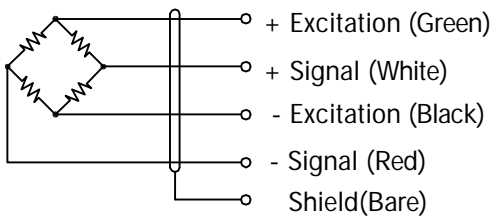

Load cell assembly is provided with 4-conductor heavy duty polyurethane cable.

AVAILABLE ACCESSORIES

- Optional top mounting plates
1klb-10klb Mounting plate:

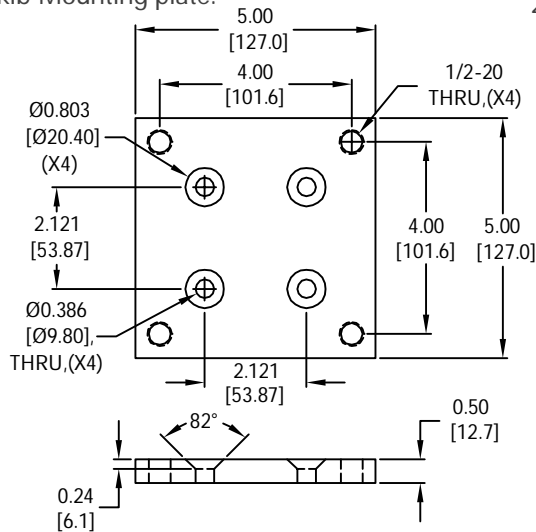

- 20klb-50klb Mounting plate:

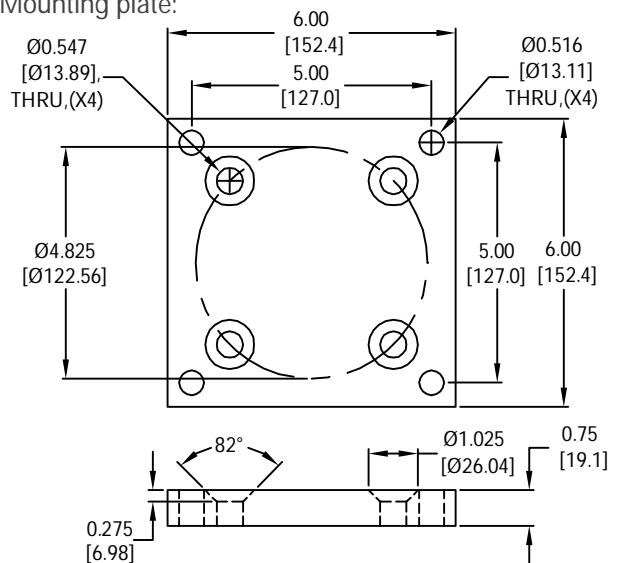

Dimensions and specifications subject to change without notice



Group Four Transducers
22 Deer Park Drive,
E. Longmeadow, MA 01028
www.groupfourtransducers.com

Phone : (800) 419 1444
Fax : (413) 525 -6182
sales@group-4.com