

The BSSPDE is a Digital Aluminum Single Point Load Cell. Ideal for use in Bench Scales, Conveyor Scales, Filling and Packaging Machines.

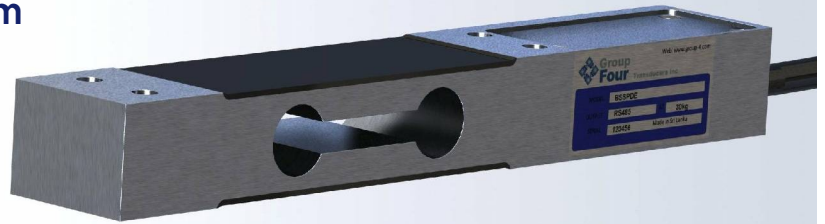

FEATURES

- Capacities from 6kg to 30kg.
- Aluminum construction.
- Environmental protection IP67.
- AD conversion rate up to 1200upd./sec.

APPLICATIONS

- Bench scales, Retail scale, Conveyor scales, Filling and Packaging machines.

OPTIONS

- Load cells can be supplied with calibration certificates as per ASTM E74.

OUTLINE DIMENSIONS

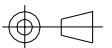
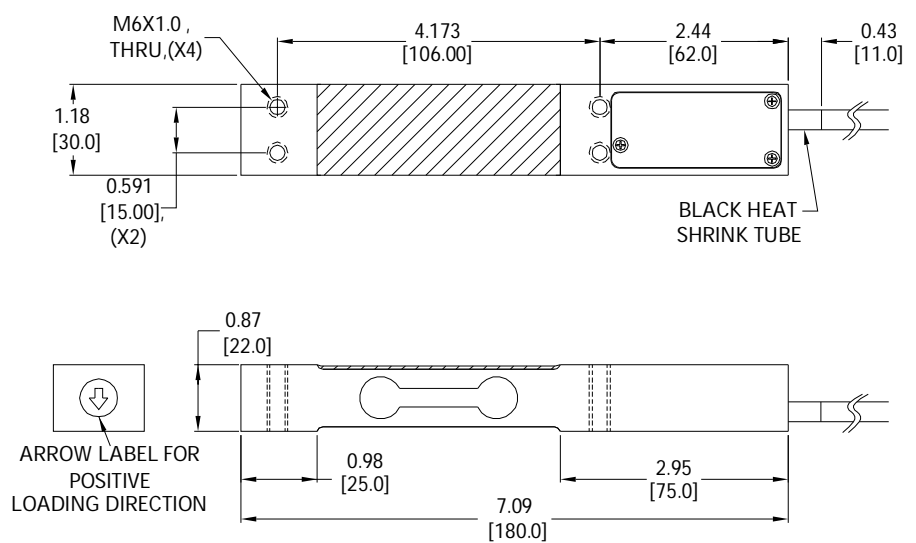

digital single point BSSPDE 4002D



WIRING

Color code	RS-232+CAN	RS-485+RS-422
Red	PWR+	PWR+
Black	GND	GND
White	RxD	Rx+
Green	TxD	Rx-
Brown	CANH	Tx+
Blue	CANL	Tx-

Cable:
24 AWG, 6 Conductor foil Shielded
black PVC cable.

SPECIFICATIONS

Model	BSSPDE	
Capacity (E _{max})	kg	6 30
Recommended min. external division	g	0.6 3
PERFORMANCES		
Accuracy class according to the OIML R60	C3	
Minimum load cell verification interval	g	E _{max} /10000
Combined Error	%FS	≤±0.017
Creep @ 30min	%FS	≤±0.017
Zero Balance, raw counts	increments	±2000
Output resolution at full load, raw counts	increments	512000
Internal AD conversion rate	upd./sec	1200
Fix, Digital Low Pass IIR Filter, Default	Hz	18 (Supress 50Hz and 60Hz Influence)
Adjustable , Digital Low Pass IIR Filter Adjustable , Digital Low Pass FIR Filter	Hz	18-0.25; Selectable in 8 Steps 40-5; Selectable in 8 Steps
Adjustable, External Output Update Rate	upd./sec	1200-9; Selectable in 8 Steps
GENERAL I/O's		
Hardware Interface, CAN Version Hardware Interface, RS Version	CAN and RS232 RS485 and RS422 (Both Four Wire)	
Data transmission rates CAN Data transm. rates RS485/RS422/RS232	kb	125;250;500;1000 9.6;19.2;38.4;57.6;115.2;230.4;460.8
Protocol CAN Protocol RS485/ RS422/ RS232	CAN Open ASCII or Modbus RTU	
Logical Input, Programmable	Trigger Level 2-30Vdc, <3mA, Ref to Gnd.	
Power supply	VDC	10-30 ≤ 0.4 Watt
INFLUENCES		
Safe Load Limit	%* E _{max}	150
Ultimate Load	%* E _{max}	300
Temperature Effect on Zero	%FS/°C	0.001
Temperature Effect on Span	%FS/°C	0.001
Temperature Range	°C	Operating: -10/+40 Storage: -40/+70
EMC performance	MID Class E2 (Industrial Locations)	
I/O Protection, All Pins	Reversed Polarity; Excess Voltage and Surge	
Isolation Body/ Electronics at 500VDC	GΩ	≥1
Vibration	2.5G Operational; 5G Non-Operational	
Cable Length	ft	5 +0.1/ -0
Environmental Protection	IP67	
Corrosion Resistance	Aluminum	

PART NUMBERS

Capacity(kg)	Option	Part No.
6	RS232 + CAN	4002D-001-01
30	RS232 + CAN	4002D-002-01

Capacity(kg)	Option	Part No.
6	RS485+RS422	4002D-001-02
30	RS485+RS422	4002D-002-02

Dimensions and specifications subject to change without notice



Pioneering Measured Solutions

Group Four Transducers

22 Deer Park Drive,
E. Longmeadow, MA 01028
www.groupfourtransducers.com

Phone : (800) 419 1444
Fax : (413) 525 -6182
sales@group-4.com