

G4610 Series Strain Gauge, Load Cell, and mV Meter

Instruction Manual



MeterView Pro

USB Install

- 1/8 DIN Digital Panel Meter with NEMA 4X, IP65 Front
- 15 mV, 30 mV, 150 mV, 300 mV unipolar; ± 15 mV, ± 25 mV, ± 150 mV, ± 250 mV bipolar Inputs
- Selectable 5 or 10 VDC Sensor Excitation @ 350 mA Max
- Dual-Line 6-Digit Display, 0.6" (15 mm) & 0.46" (12 mm)
- 2 or 4 Relays with Interlocking Capability + Isolated 4-20 mA Output Options
- Free PC-Based, On-Board, MeterView Pro USB Programming Software
- No Assembly Required
- Optional SunBright Display Models for Outdoor Applications
- Operating Temperature Range: -40 to 65°C (-40 to 149°F)
- UL & C-UL Listed. E160849; 508 Industrial Control Equipment
- Input Power Options: 85-265 VAC / 90-265 VDC or 12-24 VDC / 12-24 VAC
- Supports up to Twelve (12) 350 Ω Load Cells
- Capture or Programmable Tare Feature
- Auto-Zero Feature Eliminates Zero Drift
- Ratiometric Operation
- Programmable Display, Function Keys & Digital Input
- External 4-Relay & Digital I/O Expansion Modules
- RS-232 & RS-485 Serial Communication Options with Modbus RTU
- Password Protection
- Wide Assortment of NEMA 4X Enclosures for up to Ten Meters
- 3-Year Warranty



Group Four Transducers

22 Deer Park Drive,
E Longmeadow, MA 01028
www.groupfourtransducers.com

Phone : (800) 419 1444
Fax : (413) 525 -6182
sales@group-4.com

Disclaimer

The information contained in this document is subject to change without notice. Group Four makes no representations or warranties with respect to the contents hereof and specifically disclaims any implied warranties of merchantability or fitness for a particular purpose. See Warranty Information and Terms & Conditions on www.groupfourtransducers.com for complete details.

CAUTION

- Read complete instructions prior to installation and operation of the meter.

WARNINGS

- Risk of electric shock or personal injury.
- This product is not recommended for life support applications or applications where malfunctioning could result in personal injury or property loss. Anyone using this product for such applications does so at his/her own risk. Group Four Transducers Inc shall not be held liable for damages resulting from such improper use.

WARNING
Cancer and Reproductive Harm - www.P65Warnings.ca.gov

Limited Warranty

Group Four Transducers Inc warrants this product against defects in material or workmanship for the specified period under "Specifications" from the date of shipment from the factory. Group Four's liability under this limited warranty shall not exceed the purchase value, repair, or replacement of the defective unit. See Warranty Information and Terms & Conditions on www.groupfourtransducers.com for complete details.

Registered Trademarks

All trademarks mentioned in this document are the property of their respective owners.

© 2020 Group Four Transducers Inc.
All rights reserved.

FREE MeterView Pro Programming Software



*The meter can be powered from the Micro USB connection. When using the Micro USB connection, **DO NOT** apply AC or DC power to the meter.*

The easiest and quickest way to program your G4610 meter is to use the FREE MeterView Pro programming software. This software is loaded into the meter and connects and installs directly to your PC with a USB cable. We recommend that the first thing you do after taking the meter out of the box is connect the G4610 to your PC with the provided USB cable – do not use a different cable. **DO NOT** apply AC or DC power to the meter while your PC is connected to the meter as it will disrupt the USB connection. You don't even have to apply an input signal.

MeterView Pro programming software is intuitive, and most customers can get their meter programmed as they like without even looking in the manual.

In addition to programming, the software may be used for:

- Monitoring
- Datalogging using your PC
- Generating and saving programming files for later use

Once your meter is programmed the way you want it, you can wire it up for your application per the instructions in this manual and install it. If you find that you need to make adjustments to the programming after the meter is installed, you can use the front panel buttons and the instructions in this manual to do so.

Table of Contents

Introduction	6
Ordering Information	6
Specifications.....	7
General	7
Strain Gauge Input	8
Relays	8
Isolated 4-20 mA Transmitter Output	9
USB Connection	9
On-Board Digital Input (F4)	9
Modbus® RTU Serial Communications	9
MeterView Pro	9
Compliance Information	10
Safety	10
Electromagnetic Compatibility	10
Safety Information	10
Installation	10
Unpacking	10
Panel Mounting Instructions	11
Mounting Dimensions.....	11
Installation Overview	12
MeterView Pro Software	12
MeterView Pro Installation.....	12
Sensor Excitation Voltage Selection (EX+, EX-)	13
Connections	13
Connectors Labeling	13
Power Connections	14
Signal Connections	14
Switch Configuration	14
Shunt Calibration.....	16
Modbus RTU Serial Communications	16
Relay Connections	16
Switching Inductive Loads.....	16
4-20 mA Output Connections.....	17
Analog Output Power Supply	17
F4 Digital Input Connections	17
External Relays & Digital I/O Connections	18
Interlock Relay Feature	18
Setup and Programming	19
Overview	19
Front Panel Buttons and Status LED Indicators	19
Display Functions & Messages	20
Setting Numeric Values	22
Main Menu	22
Setting Up the Meter (SETUP)	22
Setting the Input Signal (INPUT).....	23
Setting the Display Units (UNIT).....	23
Setting the Display Units or Custom Tags (UNIT)	24
Programming the Meter (PROM)	24
Calibrating the Meter with Strain Gauge/Load Cell (EAL).....	25
Setting the Display Parameter & Intensity (DISPLAY)	26
Display Intensity (DISPLAY).....	26
Setting the Relay Operation (RELAY)	27
Setting the Relay Action.....	27
Programming Set and Reset Points	28
Setting Fail-Safe Operation.....	28
Programming Time Delay.....	28
Relay and Alarm Operation Diagrams	28
High Alarm Operation (Set > Reset)	28
Low Alarm Operation (Set < Reset)	29
High Alarm with Fail-Safe Operation (Set > Reset).....	29
Low Alarm with Fail-Safe Operation (Set < Reset)	29
Time Delay Operation	29
Pump Alternation Control Operation	30
Relay Sampling Operation	30

Relay Operation Details	31
Overview	31
Relays Auto Initialization	31
Fail-Safe Operation	31
Front Panel LEDs	31
Latching and Non-Latching Relay Operation	31
Non-Latching Relay (R <u>u</u> t <u>o</u>)	32
Non-Latching Relay with Manual Reset (R <u>o</u> n <u>o</u> R <u>u</u> t)	32
Latching Relay (L <u>o</u> c <u>u</u> t)	32
Latching Relay with Clear (L <u>o</u> c <u>u</u> t- <u>C</u> l <u>e</u> r)	32
Acknowledging Relays	33
Pump Alternation Control Applications (R <u>u</u> t <u>o</u> <u>A</u> l <u>l</u> <u>E</u> r <u>n</u>)	33
Setting Up the Interlock Relay (Force On) Feature	34
Scaling the 4-20 mA Analog Output (R<u>o</u>u<u>t</u>)	35
Setting Up the Password (P<u>R</u>55)	35
Protecting or Locking the Meter	35
Making Changes to a Password Protected Meter	35
Disabling Password Protection	35
Reset Menu (r<u>E</u>S<u>E</u>t)	35
Tare Menu (t<u>R</u>r<u>E</u>)	36
Tare Functionality (t <u>R</u> r <u>E</u>)	36
Manual Control Menu (C<u>o</u>n<u>t</u>r<u>L</u>)	36
Advanced Features Menu	36
Advanced Features Menu & Display Messages	36
Noise Filter (F <u>i</u> l <u>t</u> e <u>r</u>)	37
Noise Filter Bypass (b <u>y</u> P <u>R</u> 55)	37
Rounding Feature (r <u>o</u> u <u>n</u> d)	37
Modbus RTU Serial Communications (S <u>E</u> r <u>i</u> a <u>L</u>)	38
Select Menu (S <u>E</u> L <u>E</u> c <u>t</u>)	38
Input Signal Conditioning (F <u>u</u> n <u>c</u> t <u>i</u> o <u>n</u>)	38
Auto-Zero (R <u>u</u> t <u>o</u> <u>0</u>)	39
Low-Value Cutoff (L <u>o</u> w <u>V</u> a <u>l</u> u <u>e</u> <u>C</u> u <u>t</u> o <u>ff</u>)	39
Analog Output Programming (R <u>o</u> u <u>t</u> <u>P</u> r)	39
Programmable Function Keys User Menu (u <u>S</u> E <u>r</u>)	40
Internal Source Calibration (I <u>S</u> C <u>a</u> l)	41
Error Message (E <u>r</u> r <u>o</u> r)	41
Meter Operation	42
Front Panel Buttons Operation	42
Function Keys Operation	42
F4 Operation	42
Maximum/Minimum Readings	42
Troubleshooting	43
Diagnostics Menu (d<u>i</u>a<u>g</u>n<u>o</u>s<u>t</u>i<u>c</u>s)	43
Determining Software Version	43
Reset Meter to Factory Defaults	43
Factory Defaults & User Settings	44
Troubleshooting Tips	45
EU Declaration of Conformity	46

Table of Figures

Figure 1. 1/8 DIN Panel Cutout Dimensions	11
Figure 2. Panel Mounting Details	11
Figure 3. Meter Dimensions - Side View	11
Figure 4. Meter Dimensions - Top View	11
Figure 5. Sensor Excitation Voltage Selection.....	13
Figure 6. G4610-##0 Connectors Label.....	13
Figure 7. G4610-##2 Connectors Label.....	13
Figure 8. G4610-##3 Connectors Label.....	13
Figure 9. G4610-##4 Connectors Label.....	13
Figure 10. G4610-##5 Connectors Label.....	13
Figure 11. G4610-##7 Connectors Label.....	14
Figure 12. Power Connections	14
Figure 13. Strain Gauge Configuration Switch	14
Figure 14. Strain Gauge Powered by Internal Supply	15
Figure 15. Strain Gauge Powered by External Supply	15
Figure 16. Multiple Strain Gauges Connected Through Junction Box	15
Figure 17. mV Transducer Input Connections	15
Figure 18. Four-wire mV Transducer Connections.....	15
Figure 19. Shunt Resistor	16
Figure 20. Relay Connections.....	16
Figure 21. AC and DC Loads Protection.....	16
Figure 22. Low Voltage DC Loads Protection	16
Figure 23. 4-20 mA Output Connections	17
Figure 24. Analog Output Supply Powering Other Devices.....	17
Figure 25. F4 Digital Input Connections	17
Figure 26. Expansion Module & DIN Rail Mounting Kit.....	18
Figure 27. External Relays Module Connections.....	18
Figure 28. Digital I/O Module Connections.....	18
Figure 29. Interlock Connections	18

Introduction

The G4610 is a multipurpose, easy-to-use digital strain gauge & load cell meter ideal for weighing and force measurement applications. Its superluminous LED digits make it easily readable in smoke, dust, fog, and, with the optional SunBright display, even direct sunlight.

It accepts mV input signals up to 300 mV. With a max current of 350 mA at 10 V, it can support up to twelve (12) 350 Ω load cells (minimum load resistance of 28 Ω), making it ideal for multipoint weight measurement applications. The mV input can be scaled to display the process in two different scales; for example, pounds on display line 1 and gallons on line 2. Three of the front panel buttons can be custom-programmed for a specific operation.

The basic model includes an isolated 5 or 10VDC Sensor power supply that can be used to power the input Sensor or 24 VDC for other devices. An additional isolated 24 VDC power supply is included with the 4-20 mA output option. A digital input (F4) and micro USB port are standard on the meter.

A fully loaded G4610 meter has the following: four SPDT relays, 4-20 mA output, one 10 VDC sensor excitation, and one 24 VDC power supply. The G4610 capabilities may be enhanced by adding the following external expansion modules: four SPST relays – creating an eight-relay process meter, two digital I/O modules with four inputs and four outputs each, and RS-232 or RS-485 communication adapters.

The eight relays can be used for alarm indication or process control such as pump alternation control. The 4-20 mA isolated output, Modbus RTU serial communications, and digital I/O options make the G4610 an excellent addition to any system.

Ordering Information

Standard Models

Reorder #	Manufacturer #	Options Installed
85-265 VAC Models		
G4610-6R0	PD6100-6R0-GT	No options
G4610-6R2	PD6100-6R2-GT	2 relays
G4610-6R3	PD6100-6R3-GT	4-20 mA output
G4610-6R4	PD6100-6R4-GT	4 relays
G4610-6R5	PD6100-6R5-GT	2 relays & 4-20 mA out
G4610-6R7	PD6100-6R7-GT	4 relays & 4-20 mA out
12-24 VDC Models		
G4610-7R0	PD6100-7R0-GT	No options
G4610-7R2	PD6100-7R2-GT	2 relays
G4610-7R3	PD6100-7R3-GT	4-20 mA output
G4610-7R4	PD6100-7R4-GT	4 relays
G4610-7R5	PD6100-7R5-GT	2 relays & 4-20 mA out
G4610-7R7	PD6100-7R7-GT	4 relays & 4-20 mA out

SunBright Display Models

Reorder #	Manufacturer #	Options Installed
85-265 VAC Models		
G4610-6H0	PD6100-6H0-GT	No options
G4610-6H2	PD6100-6H2-GT	2 relays
G4610-6H3	PD6100-6H3-GT	4-20 mA output
G4610-6H4	PD6100-6H4-GT	4 relays
G4610-6H5	PD6100-6H5-GT	2 relays & 4-20 mA out
G4610-6H7	PD6100-6H7-GT	4 relays & 4-20 mA out
12-24 VDC Models		
G4610-7H0	PD6100-7H0-GT	No options
G4610-7H2	PD6100-7H2-GT	2 relays
G4610-7H3	PD6100-7H3-GT	4-20 mA output
G4610-7H4	PD6100-7H4-GT	4 relays
G4610-7H5	PD6100-7H5-GT	2 relays & 4-20 mA out
G4610-7H7	PD6100-7H7-GT	4 relays & 4-20 mA out

Manufactured by Precision Digital Corporation
233 South Street • Hopkinton, MA 01748 USA

Accessories

Model	Description
G4A1002	DIN rail mounting kit for two devices
G4A1004	4 SPST (Form A) relays module
G4A1044	4 digital inputs & 4 digital outputs module
G4A1232	RS-232 serial adapter
G4A1485	RS-485 serial adapter
G4A7485-I	RS-232 to RS-485 isolated converter
G4A8232-N	USB to RS-232 non-isolated converter
G4A-8008	USB serial adapter
G4A8485-I	USB to RS-485 isolated converter
G4A-LHB	Blue light / horn
G4A-LHG	Green light / horn
G4A-LHR	Red light / horn
G4A-LHW	White light / horn
G4A-LHY	Yellow light / horn
G4A-LH3LC-RYG	Light / horn with red, green, yellow light layers
G4A-LH5C	Light / horn choice of red, green, yellow, blue or white

Enclosures

Series	Meters	Material
G4E2300	1-10	Plastic NEMA 4X
G4E2500	1-6	Plastic NEMA 4X
G4E2600	1-6	Stainless steel NEMA 4X
G4E2700	1-6	Painted steel NEMA 4
G4E2800	1-2	Plastic NEMA 4X
G4E3400	1-3	Plastic NEMA 4X

Specifications

Except where noted all specifications apply to operation at +25°C.

General

Display	Line 1: 0.60" (15 mm) high, red LEDs Line 2: 0.46" (12 mm) high, red LEDs 6 digits each (-99999 to 999999), with lead zero blanking
Display Intensity	Eight user selectable intensity levels. Default value is six.
Display Update Rate	5/second (200 ms)
Overrange	Display flashes 999999
Underrange	Display flashes -99999
Display Assignment	The displays may be assigned to PV1, PV2, PCT, max & min, set points, PV & units, units (lower display only), net & gross weight, Modbus input, and display millivolts.
Units	Predefined: lb, kg, ounce, gram, ton, metric ton (tonne); and custom units.
Programming Methods	Four front panel buttons, digital inputs, PC and MeterView Pro software, or Modbus registers.
Noise Filter	Programmable from 2 to 199 (0 will disable filter)
Filter Bypass	Programmable from 0.1 to 99.9% of calibrated span
Recalibration	All ranges are calibrated at the factory. Recalibration is recommended at least every 12 months.
Max/Min Display	Max/min readings reached by the process are stored until reset by the user or until power to the meter is cycled.
Rounding	Select 1, 2, 5, 10, 20, 50, or 100 (e.g. rounding = 10, value = 123.45, display = 123.50).
Tare	There are three modes of tare operation: Capture Tare, Programmable Tare, and Off. See <i>Tare Functionality (t Rr E)</i> on page 36 for details.
Password	Three programmable passwords restrict modification of programmed settings. Pass 1: Allows use of function keys and digital inputs Pass 2: Allows use of function keys, digital inputs and editing set/reset points Pass 3: Restricts all programming, function keys, and digital inputs.
Non-Volatile Memory	All programmed settings are stored in non-volatile memory for a minimum of ten years if power is lost.
Power Options	85-265 VAC 50/60 Hz; 90-265 VDC, 20 W max; 12-24 VDC, 12-24 VAC, 15 W max. Powered over USB for configuration only.
Fuse	Required external fuse: UL Recognized, 5 A max, slow blow; up to 6 meters may share one 5 A fuse
Normal Mode Rejection	Greater than 60 dB at 50/60 Hz

Isolation	4 kV input-to-power line 500 V input-to-output (powered by external supply)
Overvoltage Category	Installation Overvoltage Category II: Local level with smaller transient overvoltages than Installation Overvoltage Category III.
Environmental	Operating temperature range: -40 to 65°C (-40 to 149°F) Storage temperature range: -40 to 85°C (-40 to 185°F) Relative humidity: 0 to 90% non-condensing
Connections	Removable screw terminal blocks accept 12 to 22 AWG wire, RJ45 for external relays, digital I/O, and serial communication adapters.
Enclosure	1/8 DIN, high impact plastic, UL 94V-0, color: black
Front Panel	NEMA 4X, IP65
Mounting	1/8 DIN panel cutout required: 3.622" x 1.772" (92 mm x 45 mm) Two panel mounting bracket assemblies are provided.
Tightening Torque	Screw terminal connectors: 5 lb-in (0.56 Nm)
Overall Dimensions	4.68" x 2.45" x 5.64" (119 mm x 62 mm x 143 mm) (W x H x D)
Weight	9.5 oz (269 g)
Warranty	3 years parts & labor. See Warranty Information and Terms & Conditions www.groupfourtransducers.com for complete details.

Strain Gauge Input

Inputs	Field selectable: 0-15 mV, 0-30 mV, 0-150 mV, 0-300 mV, ± 15 mV, ± 25 mV, ± 150 mV, ± 250 mV, or Modbus PV (Slave)	
Isolated Sensor Power Supply	Terminals EX+ & EX-: 10 VDC or 5 VDC $\pm 10\%$, rated @ 350 mA max. <i>Note: Do not use 24 VDC to power strain gauge bridge.</i>	
Accuracy	$\pm 0.03\%$ of calibrated span ± 1 count	
Minimum Load Resistance	14 Ω @ 5 V 28 Ω @ 10 V	
Maximum Excitation Current	350 mA @ 5 V or 10 V	
Temperature Drift	0.002% of calibrated span/ $^{\circ}$ C max from 0 to 65 $^{\circ}$ C ambient, 0.005% of calibrated span/ $^{\circ}$ C max from -30 to 0 $^{\circ}$ C ambient	
Functions	Linear with multi-point linearization	
Multi-Point Linearization	2 to 32 points for PV or PV1 2 to 8 points for PV2 (Dual-scale feature)	
Low Cutoff	0.0 to 999,999.9 (0 disables cutoff function). Point below at which display always shows zero.	
Decimal Point	Up to five decimal places or none: dddddd, dddddd, dddd, dddd, dd, or dddddd	
Calibration Range	Input Range	Minimum Span Input 1 & Input 2
	15 mV	0.2 mV
	25 mV, 30 mV	0.4 mV
	150 mV	2.0 mV
	250 mV, 300 mV	4.0 mV
	An Error message will appear if the input 1 and input 2 signals are too close together.	
Input Impedance	Strain Gauge Bridge: Greater than 10 M Ω mV Source: 200 k Ω	

Relays

Rating	2 or 4 SPDT (Form C) internal and/or 4 SPST (Form A) external; rated 3 A @ 30 VDC and 125/250 VAC resistive load; 1/14 HP (≈ 50 W) @ 125/250 VAC for inductive loads
Noise Suppression	Noise suppression is recommended for each relay contact switching inductive loads; see <i>Switching Inductive Loads</i> on page 16 for details.
Deadband	0-100% of span, user programmable
High or Low Alarm	User may program any alarm for high or low trip point. Unused alarm LEDs and relays may be disabled (turn off).
Relay Operation	<ul style="list-style-type: none"> • Automatic (non-latching) and/or manual reset • Latching (requires manual acknowledge) with or without clear • Pump alternation control (2 to 8 relays) • Sampling (based on time) • Off (disable unused relays and enable Interlock feature) • Manual on/off control mode
Relay Reset	User selectable via front panel button, F4 terminal at back of meter, external contact closure on digital inputs, or through serial communications.
Time Delay	0 to 999.9 seconds, on & off relay time delays. Programmable and independent for each relay
Fail-Safe Operation	Programmable and independent for each relay. <i>Note: Relay coil is energized in non-alarm condition. In case of power failure, relay will go to alarm state.</i>
Auto Initialization	When power is applied to the meter, relays will reflect the state of the input to the meter.
Additional Relays	An external module, model G4A1004, is available to add 4 SPST 3 A relays to the meter.

Isolated 4-20 mA Transmitter Output

Output Source	Process variable (PV), max, min, set points 1-8, Modbus input, or manual control mode		
Scaling Range	1.000 to 23.000 mA for any display range		
Calibration	Factory calibrated: 0.00 to 100.00 = 4-20 mA output		
Analog Output Programming	1.000 mA minimum and 23.000 mA maximum for all parameters: overrange, underrange, max, min, and break		
Accuracy	± 0.1% of span ± 0.004 mA		
Temperature Drift	0.4 µA/°C max from 0 to 65°C ambient, 0.8 µA/°C max from -40 to 0°C ambient <i>Note: Analog output drift is separate from input drift.</i>		
Isolated Transmitter Power Supply	Terminals I+ & R: 24 VDC ± 10% isolated from the input at >500 V. May be used to power the 4-20 mA output or other devices (except load cell/strain gauge). Refer to <i>Connectors Labeling</i> on page 13 and <i>Figure 23. 4-20 mA Output Connections</i> on page 17. All models rated @ 40 mA max.		
External Loop Power Supply	35 VDC maximum		
Output Loop Resistance	Power supply	Minimum	Maximum
	24 VDC	10 Ω	700 Ω
	35 VDC (external)	100 Ω	1200 Ω

USB Connection

Function	Programming only
Compatibility	USB 2.0 Standard, Compliant
Connector Type	Micro-B receptacle
Cable	USB A Male to Micro-B Cable
Driver	Microsoft® Windows® XP/Vista/7/8/10
Power	USB port provides power to the meter. DO NOT apply AC or DC power to the meter while the USB port is in use.

On-Board Digital Input (F4)

Function	Operate tare function, remote operation of front-panel buttons, acknowledge/reset relays, reset max/min values. See <i>Function Keys & Digital I/O Available Settings</i> on page 40 for a complete list of capabilities.
Contacts	3.3 VDC on contact. Connect normally open contacts across F4 to COM
Logic Levels	Logic High: 3 to 5 VDC Logic Low: 0 to 1.25 VDC
Additional I/O	Up to 2 external modules, model G4A1044 with 4 digital inputs and 4 digital outputs each can be added.

Modbus® RTU Serial Communications

Slave ID	1 – 247 (Meter address)
Baud Rate	300 – 19,200 bps
Transmit Time Delay	Programmable between 0 and 199 ms
Data	8 bit (1 start bit, 1 or 2 stop bits)
Parity	Even, Odd, or None with 1 or 2 stop bits
Byte-to-Byte Timeout	0.01 – 2.54 second
Turn Around Delay	Less than 2 ms (fixed)

Note: Refer to the G4610 Modbus Register Tables located at www.groupfourtransducers.com for details.

MeterView Pro

Availability	Download directly from meter or from www.groupfourtransducers.com
System Requirements	Microsoft® Windows® XP/Vista/7/8/10
Communications	USB 2.0 (for programming only) (Standard USB A to Micro USB B) RS-232 adapter, RS-485 adapter and RS-485 to USB converter (programming, monitoring, and data logging)
Configuration	Configure meters one at a time
Power	USB port provides power to the meter. DO NOT apply AC or DC power to the meter while the USB port is in use.

Compliance Information

Safety

UL & c-UL Listed	USA & Canada UL 508 Industrial Control Equipment
UL File Number	E160849
Front Panel	UL Type 4X, NEMA 4X, IP65; panel gasket provided
Low Voltage Directive	EN 61010-1:2010 Safety requirements for measurement, control, and laboratory use

Electromagnetic Compatibility

Emissions	EN 55022:2010 Class A ITE emissions requirements
Radiated Emissions	Class A
AC Mains Conducted Emissions	Class A
Immunity	EN 61326-1:2013 Measurement, control, and laboratory equipment EN 61000-6-2:2005 EMC heavy industrial generic immunity standard
RFI - Amplitude Modulated	80 -1000 MHz 10 V/m 80% AM (1 kHz) 1.4 - 2.0 GHz 3 V/m 80% AM (1 kHz) 2.0 - 2.7 GHz 1 V/m 80% AM (1 kHz)
Electrical Fast Transients	±2kV AC mains, ±1kV other
Electrostatic Discharge	±4kV contact, ±8kV air
RFI - Conducted	10V, 0.15-80 MHz, 1kHz 80% AM
AC Surge	±2kV Common, ±1kV Differential
Surge	1KV (CM)
Power-Frequency Magnetic Field	30 A/m 70%V for 0.5 period
Voltage Dips	40%V for 5 & 50 periods 70%V for 25 periods
Voltage Interruptions	<5%V for 250 periods

Note:

Testing was conducted on meters installed through the covers of grounded metal enclosures with cable shields grounded at the point of entry representing installations designed to optimize EMC performance.

Safety Information

CAUTION

- Read complete instructions prior to installation and operation of the meter.

WARNINGS

- Risk of electric shock or personal injury.
- Hazardous voltages exist within enclosure. Installation and service should be performed only by trained service personnel.

Installation

There is no need to remove the meter from its case to complete the installation, wiring, and setup of the meter for most applications.

Instructions are provided for changing the sensor power supply to output 5 or 10 VDC instead of 24 VDC. See *Sensor Excitation Voltage Selection (EX+, EX-)* on page 13.

Unpacking

Remove the meter from box. Inspect the packaging and contents for damage. Report damages, if any, to the carrier.

If any part is missing or the meter malfunctions, please contact your supplier or the factory for assistance.

Panel Mounting Instructions

- Prepare a standard 1/8 DIN panel cutout – 3.622" x 1.772" (92 mm x 45 mm). Refer to *Figure 1. 1/8 DIN Panel Cutout Dimensions* below for more details.
- Clearance: allow at least 6.0" (152 mm) behind the panel for wiring.
- Panel thickness: 0.04" - 0.25" (1.0 mm - 6.4 mm). Recommended minimum panel thickness to maintain Type 4X rating: 0.06" (1.5 mm) steel panel, 0.16" (4.1 mm) plastic panel.
- Remove the two mounting brackets provided with the meter (back-off the two screws so that there is ¼" (6.4 mm) or less through the bracket. Slide the bracket toward the front of the case and remove).
- Insert meter into the panel cutout.
- Install mounting brackets and tighten the screws against the panel. To achieve a proper seal, tighten the mounting bracket screws evenly until meter is snug to the panel along its short side. **DO NOT OVER TIGHTEN**, as the rear of the panel may be damaged.

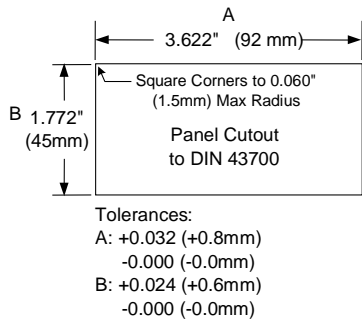
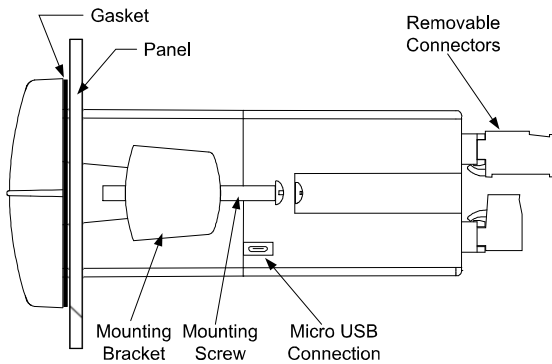

Figure 1. 1/8 DIN Panel Cutout Dimensions



DO NOT apply AC or DC power to the meter when using the Micro USB connection.

Figure 2. Panel Mounting Details

Mounting Dimensions

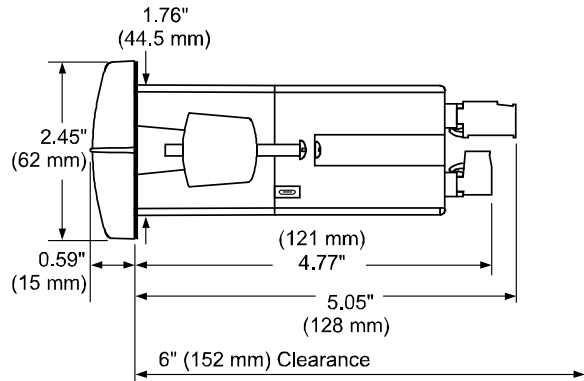

Figure 3. Meter Dimensions - Side View

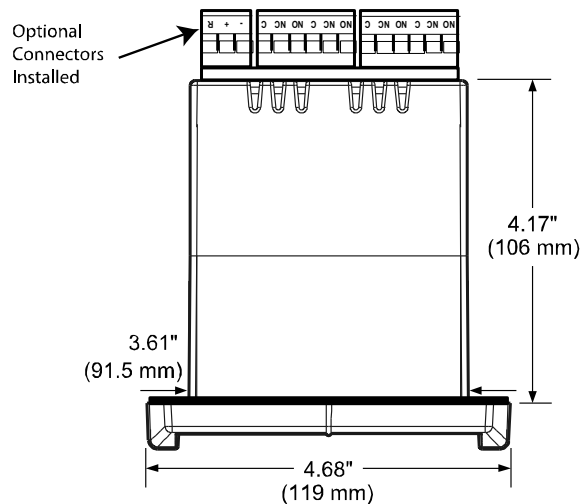

Figure 4. Meter Dimensions - Top View

Installation Overview

We recommend the following sequence for getting the meter into service:

1. **DO NOT** apply AC or DC power to the meter.
2. Connect the meter to the PC with the USB cable provided. **DO NOT** use a different USB cable.
3. If MeterView Pro (MVPro) is already installed in your computer, then the program will launch automatically in most systems. If the program does not start automatically, double-click on the MVPro icon.
4. If MVPro is not installed, follow the instructions provided below.
5. Use MVPro to configure the meter for your application.
6. Disconnect the USB cable from the meter.
7. Apply power and signal and check operation of the meter.
8. Install the meter and put into service.
9. Make any programming adjustments using the front panel buttons.

MeterView Pro Software

The easiest and quickest way to program your G4610 meter is to use the FREE MeterView Pro programming software. This software is loaded into the meter and connects and installs directly to your PC with the USB cable provided. **DO NOT** use a different USB cable. We recommend that the first thing you do after taking the meter out of the box is connect the G4610 to your PC with the provided USB cable. **DO NOT** apply AC or DC power to the meter while your PC is connected to the meter as it will disrupt the USB connection. It is not necessary to apply an input signal.

MeterView Pro programming software is intuitive, and most customers can get their meter programmed as they like without even looking in the manual.

MeterView Pro Installation

1. Connect one end of the provided USB cable to the meter and the other end to the computer. The computer will automatically install the driver software it needs to talk to the meter. Follow the on-screen instructions and allow sufficient time for the process to complete. This can take a few minutes. If the process is interrupted, then it could leave the system in an unstable condition.

⚠ WARNINGS

- Only one meter may be connected at a time. Attaching multiple meters will cause a conflict with the meter software.
- **DO NOT** apply AC or DC power to the meter when using the Micro USB connection.

2. Once the driver is installed, an AutoPlay dialog should appear for the drive "MAINSTAL." Click "Open folder to view files."

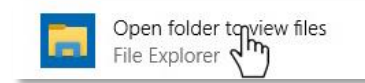

If the computer does not display an AutoPlay dialog for the drive "MAINSTAL," you should open My Computer and double-click on the drive labeled "MAINSTAL."

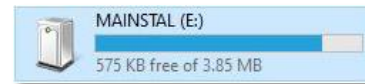

3. Double-click on the file named "MAStart." The program will open a few windows and install two programs on your computer. Simply follow the on-screen instructions until you see one of the dialogs below. If you receive a "User Account Control" warning, click "Yes."

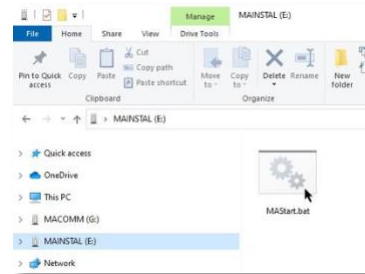

4. Click "Configure" to begin programming your meter.

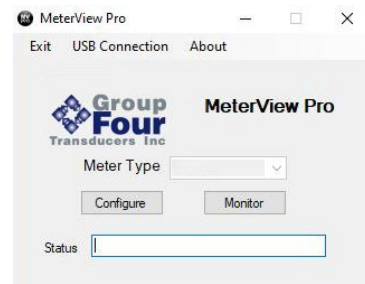

Note: If "Update" appears, click cancel. Go to www.groupfourtransducers.com for details on an update.

⚠ WARNING

- **DO NOT** unplug the meter while the new installation files are being written to it. The meter will display μV during the process and you will receive an on-screen notification once the process is complete.

Sensor Excitation Voltage Selection (EX+, EX-)

All meters, including models equipped with the 12-24 VDC power option, are shipped from the factory configured to provide 10 VDC excitation for the sensor.

If the sensor requires 5 VDC excitation, the internal jumper J3 must be configured accordingly.

To access the voltage selection jumper:

1. Remove all the wiring connectors.
2. Unscrew the back cover.
3. Slide out the back cover by about 1½ inches.
4. Configure the J3 jumper, located behind the input signal connector, for the desired excitation voltage as shown.

CAUTION

- Do not use 24V to power a strain gauge bridge. The 24 V jumper configuration should only be used for mV input applications from 4 wire sensors.

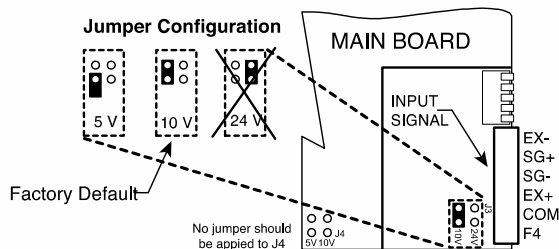

Figure 5. Sensor Excitation Voltage Selection

Connections

All connections are made to removable screw terminal connectors located at the rear of the meter.

CAUTION

- Use copper wire with 60°C or 60/75°C insulation for all line voltage connections. Observe all safety regulations. Electrical wiring should be performed in accordance with all applicable national, state, and local codes to prevent damage to the meter and ensure personnel safety.

Connectors Labeling

The connectors' label, affixed to the meter, shows the location of all connectors available with requested configuration.

Note: ## on the following figures refers to power and display options. (Example: G4610-6H5)

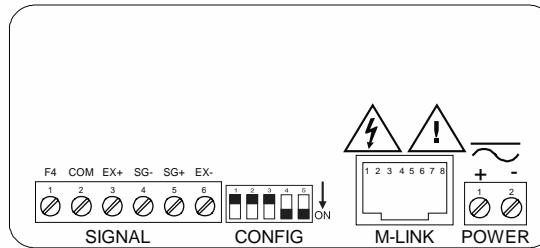

Figure 6. G4610-##0 Connectors Label

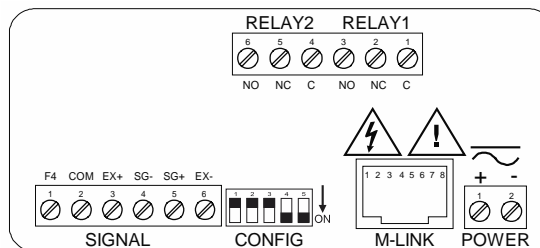

Figure 7. G4610-##2 Connectors Label

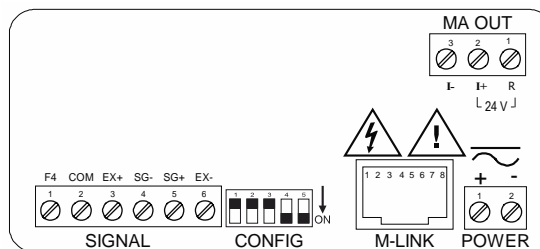

Figure 8. G4610-##3 Connectors Label

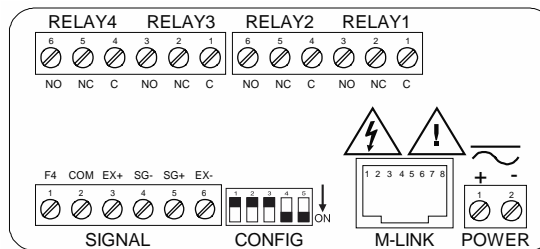

Figure 9. G4610-##4 Connectors Label

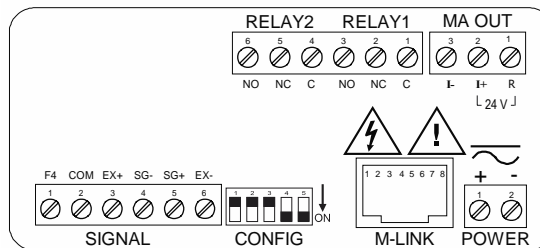

Figure 10. G4610-##5 Connectors Label

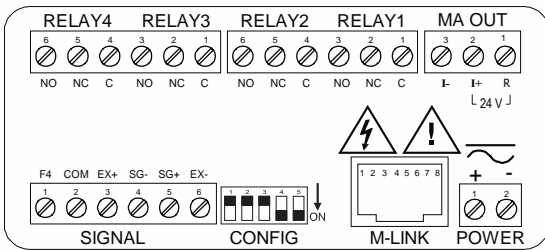

Figure 11. G4610-##7 Connectors Label

WARNING

- **DO NOT** connect any equipment other than Group Four’s expansion modules, cables, or meters to the RJ45 M LINK connector. Otherwise damage will occur to the equipment and the meter.

Power Connections

Power connections are made to a two-terminal connector labeled POWER. The meter will operate regardless of DC polarity connection. The + and - symbols are only a suggested wiring convention.

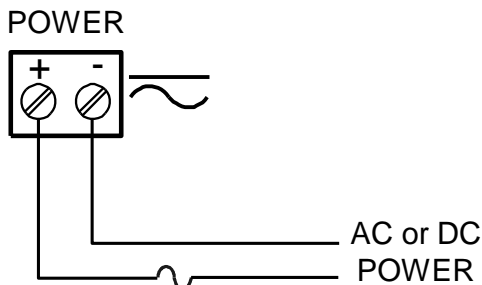

Required External Fuse:
5 A max, 250 V Slow Blow

Figure 12. Power Connections

Signal Connections

Signal connections are made to a six-terminal connector labeled SIGNAL. The EX+ and EX- terminals are used to sense the sensor excitation voltage for ratiometric operation, when the sensor is powered externally (switch 1 is off).

Switch Configuration

Setup and programming is performed both through the front panel buttons and switch settings shown below. The switch configuration must correspond to the *Setup and Programming* starting on page 19 (same range, type, etc.).

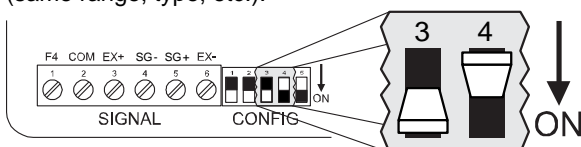

Figure 13. Strain Gauge Configuration Switch

Excitation (Switch 1)

The excitation switch designates whether the meter will use its internal power supply or an external power supply.

OFF	Excitation	External Excitation	When switch is turned OFF, an external power supply is used.
ON	Excitation	Internal Excitation	When switch is turned ON, the G4610’s power supply is used.

Range (Switch 2)

The range switch adjusts the gain of the internal circuitry. Narrower ranges require more amplification.

OFF	Range	Lower internal gain	Turn this switch OFF for the following input ranges: 150, 300, ±150, or ±250 mV.
ON	Range	Higher internal gain	Turn this switch ON for the following input ranges: 15, 30, ±15, or ±25 mV.

Polarity (Switch 3)

The polarity switch selects whether the range is unipolar and starts at zero (i.e. 0 to 30 mV) or bipolar and starts at a negative value, or below zero (i.e. -15 to +15 mV).

OFF	Polarity	Range starts below zero (bipolar)	Turn this switch OFF for the following input ranges: ±15, ±25, ±150, or ±250 mV.
ON	Polarity	Range starts at zero (unipolar)	Turn this switch ON for the following input ranges: 15, 30, 150, or 300.

Source (Switch 4)

The source switch tells the G4610 whether the input is a strain gauge bridge (i.e. *Figure 16. Multiple Strain Gauges Connected Through Junction Box*, page 15), or it is a signal from a 2 or 4 wire transducer, or mV source (i.e. *Figure 17. mV Transducer Input Connections*, page 15)

OFF	Source	Source is strain gauge bridge	Turn this switch OFF if the source is a strain gauge bridge
ON	Source	Source is mV input transducer	Turn this switch ON if the connected source is a transducer*

*Ratio should be set to NO in Setup Input Menu

Shunt Resistor (Switch 5)

The G4610 provides a means of simulating strain in a strain gauge bridge circuit via a 60.4KΩ shunt resistor included in the meter. This will simulate an approximate 70% full-scale load in the case of a 350Ω strain bridge.

OFF	Shunt	Shunt resistor is disconnected from the input bridge.	Turn this switch OFF to remove the shunt resistor
ON	Shunt	Shunt resistor is connected to the input bridge.	Turn switch ON when you want to simulate a strain load

Strain Gauge Connections

The following figures show examples of strain gauge connections.

There is a 5-position DIP switch (CONFIG) to set up the input ranges and sensor excitation.

NOTE: Refer to Switch Configuration on page 14 for proper configuration switch positioning.

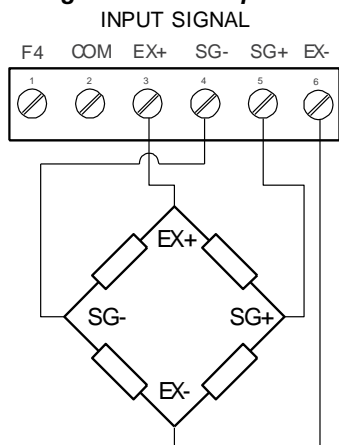

Figure 14. Strain Gauge Powered by Internal Supply

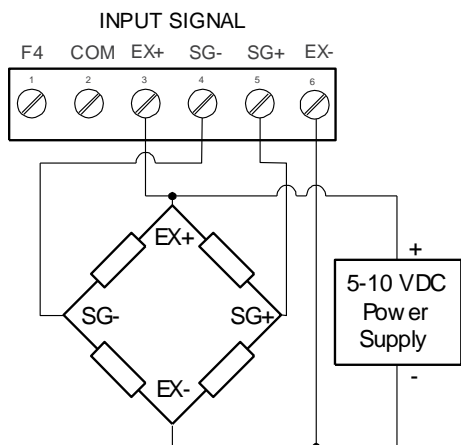

Figure 15. Strain Gauge Powered by External Supply

NOTE: Refer to Switch Configuration on page 14 for proper configuration switch positioning.

When connecting multiple strain gauges to the meter, each must be wired in parallel. This is typically done with the use of a junction box.

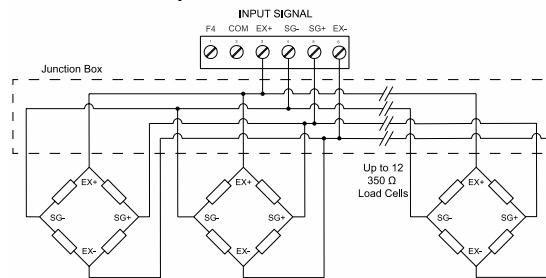

Figure 16. Multiple Strain Gauges Connected Through Junction Box

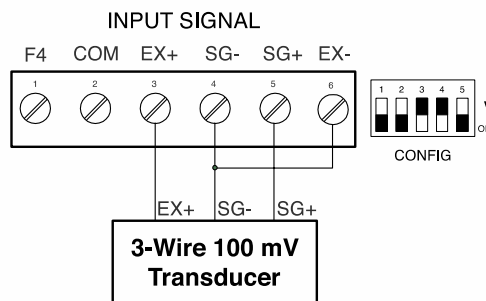

Figure 17. mV Transducer Input Connections

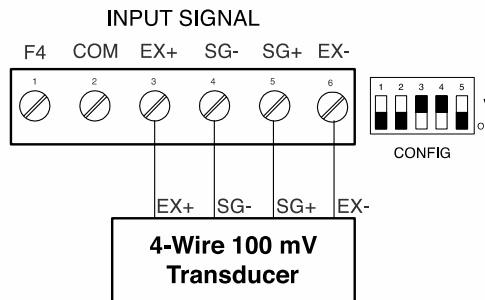

Figure 18. Four-wire mV Transducer Connections

Notes

- Two-wire mV signals: Connect positive to SG+ and negative to SG-
- Three-wire transducer: Connect EX- to SG-.

Shunt Calibration

The G4610 is equipped with a means of simulating strain in a strain gauge bridge circuit, via a shunt resistor included inside the meter. This technique is performed by enabling the “shunt resistor” switch (switch 5), which in turn shunts one leg of a connected strain bridge with a predetermined resistive load (60.4k). This technique can be used as a means of verifying instrumentation by simulating a physical input. With no load connected, the enabling of the shunt resistor (switch 5) will simulate approximately a 70% F.S. load in the case of a 350Ω Strain Bridge.

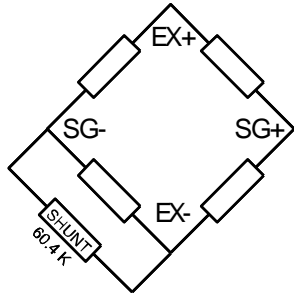

Figure 19. Shunt Resistor

Modbus RTU Serial Communications

Serial communications connection is made to an RJ45 connector labeled M-LINK. Use the G4A1232 for RS-232 interfacing or the G4A1485 for RS-485 interfacing. The same port is used for interfacing with all expansion modules (e.g. external relays, digital I/O).

Relay Connections

Relay connections are made to two six-terminal connectors labeled RELAY1 – RELAY4. Each relay’s C terminal is common only to the normally open (NO) and normally closed (NC) contacts of the corresponding relay. The relays’ C terminals should not be confused with the COM (common) terminal of the INPUT SIGNAL connector.

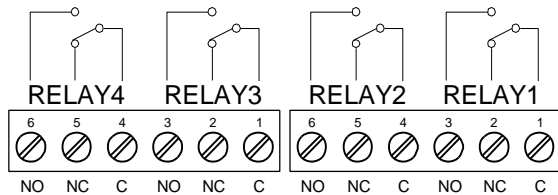

Figure 20. Relay Connections

Switching Inductive Loads

The use of snubbers to suppress electrical noise is strongly recommended when switching inductive loads to prevent disrupting the microprocessor’s operation. The snubbers also prolong the life of the relay contacts. Suppression can be obtained with resistor-capacitor (RC) networks assembled by the user or purchased as complete assemblies. Refer to the following circuits for RC network assembly and installation:

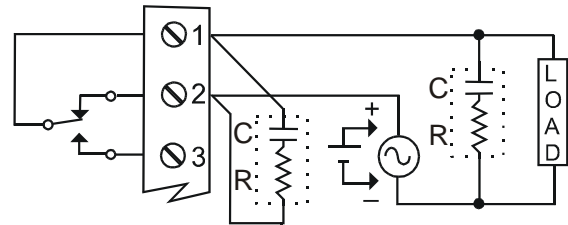

Figure 21. AC and DC Loads Protection

Choose R and C as follows:

R: 0.5 to 1 Ω for each volt across the contacts

C: 0.5 to 1 μF for each amp through closed contacts

Notes:

1. Use capacitors rated for 250 VAC.
2. RC networks may affect load release time of solenoid loads. Check to confirm proper operation.
3. Install the RC network at the meter’s relay screw terminals. An RC network may also be installed across the load. Experiment for best results.

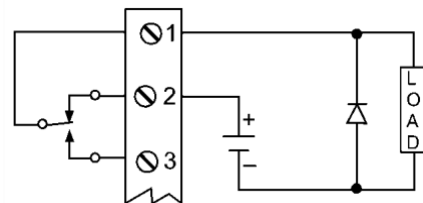

Use a diode with a reverse breakdown voltage two to three times the circuit voltage and forward current at least as large as the load current.

Figure 22. Low Voltage DC Loads Protection

Note: Relays are de-rated to 1/14th HP (50 watts) with an inductive load.

4-20 mA Output Connections

Connections for the 4-20 mA transmitter output are made to the connector terminals labeled mA OUT. The 4-20 mA output may be powered internally or from an external power supply.

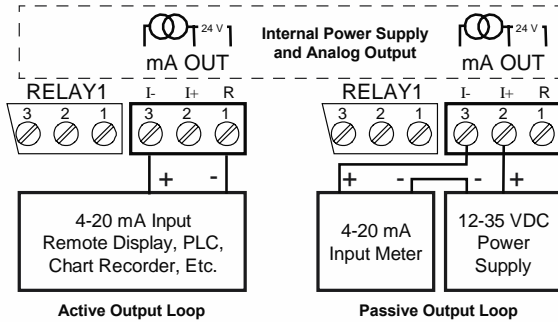

Figure 23. 4-20 mA Output Connections

Analog Output Power Supply

If the analog output is not using the 24 VDC supply to power the output loop, it can be used for other things. The I+ Terminal is the +24 V and the R terminal is the return.

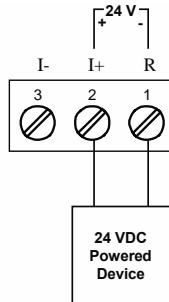

Figure 24. Analog Output Supply Powering Other Devices

F4 Digital Input Connections

A digital input, F4, is standard on the meter. This digital input should be connected with a normally open contact across F4 and COM, or with an active low signal applied to F4. It can be used to operate the tare function, for remote operation of front-panel buttons, to acknowledge/reset relays, or to reset max/min values. See *Function Keys & Digital I/O Available Settings* on page 40 for a complete list of capabilities.

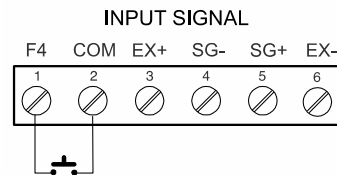

Figure 25. F4 Digital Input Connections

External Relays & Digital I/O Connections

The relay and the digital I/O expansion modules G4A1004 & G4A1044 are connected to the meter using a CAT5 cable provided with each module. The two RJ45 connectors on the expansion modules are identical and interchangeable; they are used to connect additional modules to the system.

Note: The jumper located between the RJ45 connectors of the G4A1044 must be removed on the second digital I/O module in order for the system to recognize it as module #2.

⚠ WARNING

- **DO NOT** connect or disconnect the expansion modules with the power on! More detailed instructions are provided with each optional expansion module.



Figure 26. Expansion Module & DIN Rail Mounting Kit

Interlock Relay Feature

As the name implies, the interlock relay feature reassigns one, or more, alarm/control relays for use as interlock relay(s). Interlock contact(s) are wired to digital input(s) and activate the interlock relay. This feature is enabled by configuring the relay, and the corresponding digital input(s), see *Setting Up the Interlock Relay (Force On) Feature* on page 34.

In the example below, an Interlock Contact switch is connected to a digital input, which will be used to force on (energize) the Interlock Relay. The Interlock Relay and the Control Relay are connected in series with the load.

- When the Interlock Contact is closed (safe), the Interlock Relay energizes, allowing power to flow to the Control Relay; the corresponding front panel LED is on.
- When the Interlock Contact is open, the corresponding front panel LED flashes (locked out), the Interlock Relay is de-energized, preventing power from flowing to the Control Relay and the load.

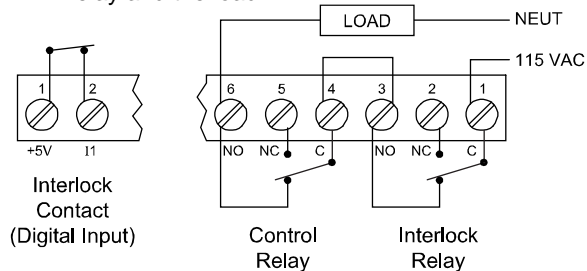

Figure 29. Interlock Connections

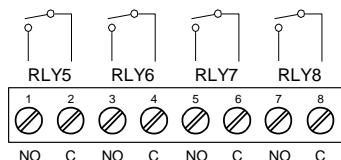

Figure 27. External Relays Module Connections

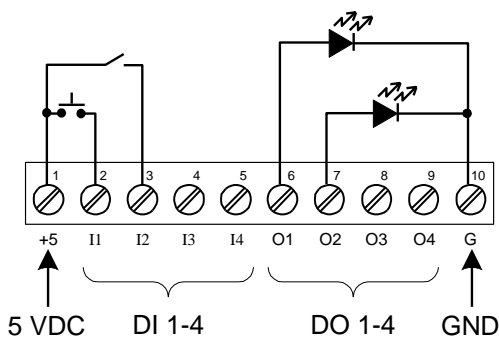

Figure 28. Digital I/O Module Connections

Setup and Programming

There is **no need to recalibrate** the meter when first received from the factory. The meter is **factory calibrated** prior to shipment for millivolts with calibration equipment that is certified to NIST standards.

Overview

There is a 5-position DIP switch to set the meter input selection. See *Switch Configuration* on page 14 to setup the switch.

Setup and programming is done through the front panel buttons.

After power and input signal connections have been completed and verified, apply power to the meter.

Front Panel Buttons and Status LED Indicators



Button Symbol	Description	LED	Status
	Menu	1-8	Alarm 1-8 indicator
	Right arrow/F1 Zero meter	1-8 M	Flashing: Relay in manual control mode
	Up arrow/F2 Reset tare	T	Flashing: Tare
	Enter/F3 Tare	G	Gross
<p><i>Note:</i> F4 is a digital input. Alarms 5-8 are enabled when relay expansion module is installed.</p>		1-8	Flashing: Relay interlock switch open
		<p><i>Note:</i> LEDs for relays in manual mode flash with the "M" LED every 10 seconds. "M" flashing by itself indicates Aout – manual control is used.</p>	

- Press the Menu button to enter or exit the Programming Mode at any time.
- Press the Right arrow button to move to the next digit during digit or decimal point programming.
- Press or hold the Up arrow button to scroll through the menus, decimal point, or to increment the value of a digit.
- Press the Enter button to access a menu or to accept a setting.
- Press and hold the Menu button for three seconds to access the advanced features of the meter.

Display Functions & Messages

The meter displays various functions and messages during setup, programming, and operation. The following table shows the main menu functions and messages in the order they appear in the menu.

Display Functions & Messages		
Display	Parameter	Action/Setting Description
SEtUP	Setup	Enter Setup menu
INPUt	Input	Enter Input selection menu
POLR	Polar	Enter unipolar or bipolar selection menu
uni	Unipolar	Press Enter to select operation with positive signals only (e.g. 0-30 mV)
bi	Bipolar	Press Enter to select operation with positive & negative signals (e.g. ±15 mV)
RNGE	Range	Enter range selection menu
15 mV	15 mV	Set meter for 15 mV input (uni/bi)
25 mV	25 mV	Set meter for ±25 mV input (bi)
30 mV	30 mV	Set meter for 30 mV input (uni)
150 mV	150 mV	Set meter for 150 mV input (uni/bi)
250 mV	250 mV	Set meter for ±250 mV input (bi)
300 mV	300 mV	Set meter for 300 mV input (uni)
RATI	Ratiometric	Press Enter to select ratiometric operation to compensate for excitation changes.
DSCALE	Dual-Scale	Press Enter to select dual-scale display (Select Yes or No)
UNITS	Units	Select the display units/tags
DEC Pt	Decimal point	Set decimal point
PV 1	PV1	PV1 decimal point (dual-scale)
PV 2	PV2	PV2 decimal point (dual-scale)
PRoG	Program	Enter the Program menu

Display Functions & Messages		
Display	Parameter	Action/Setting Description
SCALE	Scale	Enter the Scale menu
SCALE 1	Scale 1	Enter the Scale menu for PV1
SCALE 2	Scale 2	Enter the Scale menu for PV2
CAL	Calibrate	Enter the Calibration menu
INP 1	Input 1	Calibrate input 1 signal or program input 1 value
DIS 1	Display 1	Program display 1 value
INP 2	Input 2	Calibrate input 2 signal or program input 2 value (up to 32 points)
DIS 2	Display 2	Program display 2 value (up to 32 points)
Error	Error	Error, calibration not successful, check signal or programmed value
DISPLAY	Display	Enter the Display menu
LINE 1	Line 1	Press Enter to assign the upper display parameter (default: PV)
LINE 2	Line 2	Press Enter to assign the lower display parameter (default: engineering units)
DI INT	Display intensity	Set display intensity level from 1 to 8
RELAY	Relay	Enter the Relay menu
REL 1	Relay 1	Relay 1 setup
ACT 1	Action 1	Set relay 1 action
Auto	Automatic	Set relay for automatic reset
Auto-manual	Auto-manual	Set relay for automatic & manual reset any time
LATCH	Latching	Set relay for latching operation
LATCH-cleared	Latching-cleared	Set relay for latching operation with manual reset only after alarm condition has cleared
ALTERN	Alternate	Set relay for alternation control

Display Functions & Messages		
Display	Parameter	Action/Setting Description
SRn rPL	Sampling	Set relay for sampling operation
OFF	Off	Disable relay and front panel status LED (Select Off to enable Interlock feature)
SEt 1	Set 1	Program set point 1
rSEt 1	Reset 1	Program reset point 1
rLY 2	Relay 2	Relays 2-8 setup <i>Note: Relays 5-8 are shown, only if expansion relay module is installed.</i>
FRILSF	Fail-safe	Enter Fail-safe menu
FLS 1	Fail-safe 1	Set relay 1 fail-safe operation
on	On	Enable fail-safe operation
FLS 2	Fail-safe 2	Set relays 2-8 fail-safe operation
dELAY	Delay	Enter relay Time Delay menu
dLY 1	Delay 1	Enter relay 1 time delay setup
On 1	On 1	Set relay 1 On time delay
OFF 1	Off 1	Set relay 1 Off time delay
dLY 2	Delay 2	Enter relays 2-8 time delay setup
Rout	Analog output	Enter the Analog output scaling menu
d 1 1	Display 1	Program display 1 value
Out 1	Output 1	Program output 1 value (e.g. 4.000 mA)
d 1 2	Display 2	Program display 2 value
Out 2	Output 2	Program output 2 value (e.g. 20.000 mA)
rESEt	Reset	Press Enter to access the Reset menu
rSEt H 1	Reset high	Press Enter to reset max display
rSEt Lo	Reset low	Press Enter to reset min display
rSEt HL	Reset high & low	Press Enter to reset max & min displays

Display Functions & Messages		
Display	Parameter	Action/Setting Description
rSEt t r	Reset tare	Press Enter to reset tare
tRrE	Tare	Enter Tare menu
CRPtur	Capture	Press Enter to set meter to capture tare using the Tare button
PrOg t	Programmable	Press Enter to set meter to programmable tare and enter a value
OFF	Off	Press Enter to disable the tare function
Control	Control	Enter Manual Control menu
Ruto	Automatic	Press Enter to set meter for automatic operation
man	Manual	Press Enter to manually control relays or analog output operation
PR55	Password	Enter the Password menu
PR55 1	Password 1	Set or enter Password 1
PR55 2	Password 2	Set or enter Password 2
PR55 3	Password 3	Set or enter Password 3
unloc	Unlocked	Program password to lock meter
locd	Locked	Enter password to unlock meter
999999 -999999	Flashing	Over/under range condition

Setting Numeric Values

The numeric values are set using the Right and Up arrow buttons. Press Right arrow to select next digit and Up arrow to increment digit value. The digit being changed is displayed brighter than the rest. Press and hold up arrow to auto-increment the display value. Press the Enter button, at any time, to accept a setting or Menu button to exit without saving changes.

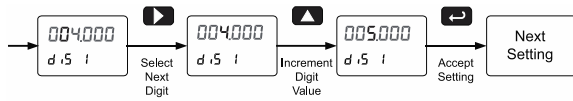

Main Menu

The main menu consists of the most commonly used functions: *Setup*, *Reset*, *Tare*, *Control*, and *Password*.

- Press Menu button to enter Programming Mode then press the Up arrow button to scroll main menu.
- Press Menu, at any time, to exit and return to Run Mode. Changes made to settings prior to pressing Enter are not saved.
- Changes to the settings are saved to memory only after pressing Enter.
- The display moves to the next menu every time a setting is accepted by pressing Enter.

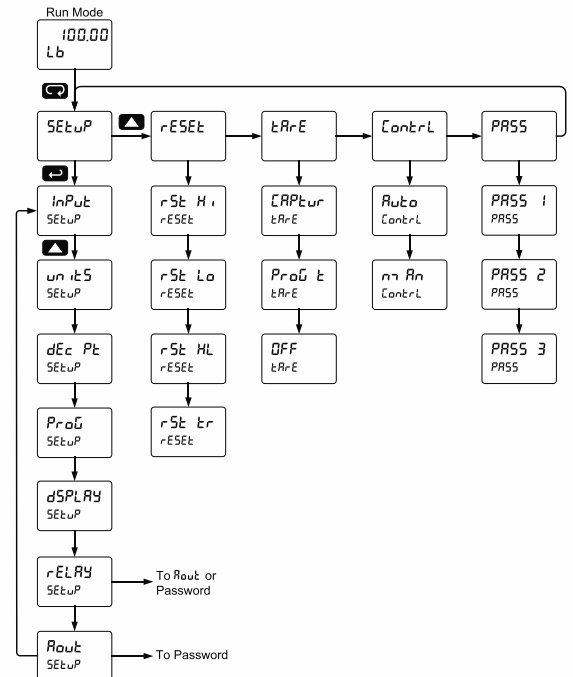

Setting Up the Meter (SEtUP)

The *Setup* menu is used to select:

1. Unipolar (e.g. 0-30 mV) or bipolar (e.g. ± 25 mV) polarity, input range, ratiometric operation, and dual-scale feature
2. Engineering units
3. Decimal point position
4. Program scaling or live calibration
5. Display parameter and intensity
6. Relay operation
7. 4-20 mA analog output scaling

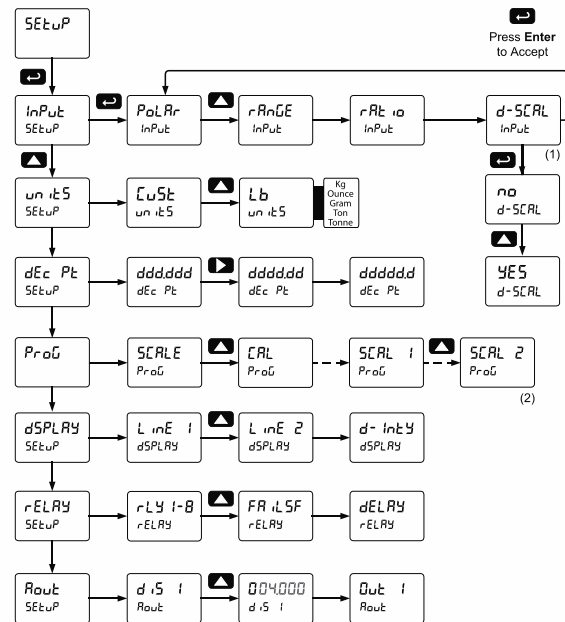

Notes:
 1. Use the d-ScRL selection to activate the dual-scale level feature - PV1 & PV2. Set d-ScRL to no if both displays are to be used for anything other than PV1 & PV2.
 2. ScRL i & ScRL 2 are displayed if d-ScRL is selected under the Setup Input menu. They correspond to the PV2 & PV2 scales.

Setting the Input Signal (InPut)

Enter the *Input* menu to set up the input polarity, range, ratiometric operation, and dual-scale feature.

The meter is capable of accepting any signal from -250 to 250 mV in bipolar mode or up to 300 mV in unipolar mode.

After selecting “Yes” or “No” for *ratio*, *d-SCALE* is displayed. Selecting “Yes” enables the dual-scale feature, allowing scaling of the same input in two different scales (for PV1 & PV2) or displaying the percentage of PV1.

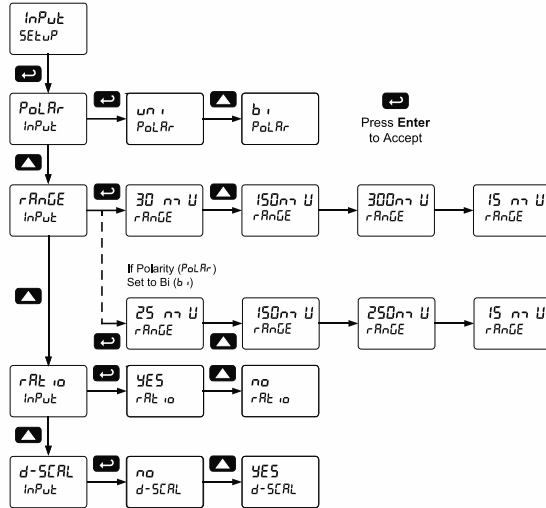

Input Polarity Selection (POLAR)

Select unipolar operation for inputs in ranges from 0 to 300 mV and select bipolar operation for inputs in ranges from -250 mV to +250 mV. This setting determines the selectable ranges for the millivolt input.

NOTE: Refer to *Switch Configuration on page 14 for proper configuration switch positioning.*

Range Selection (rRnGE)

This menu is used to select the input range. The selections listed are determined by the *Polarity* setting.

Unipolar mode: 0-15 mV, 0-30 mV, 0-150 mV, 0-300 mV

Bipolar mode: ±15 mV, ±25 mV, ±150 mV, ±250 mV

NOTE: Refer to *Switch Configuration on page 14 for proper configuration switch positioning.*

Ratiometric Operation (rRt io)

Ratiometric operation corrects the measured strain gauge signal for up to ±5% variation of either the internal or external excitation power supply. In order to use the ratiometric operation, the ratiometric operation menu must be set to yes (YES).

Dual-Scale (d-SCALE)

The mV input can be displayed in two different scales, by enabling the dual-scale feature in the *Setup-Input* menu. See *Dual-Scale (d-SCALE)* on page 23.

To enable the dual-scale feature you must select *d-SCALE* in the Input selection menu.

Setting the Display Units (un itS)

Enter the pre-defined engineering unit or custom unit. The pre-defined units have automatic conversion factors. This unit will be displayed if *d un itS* is selected as the lower display parameter. See *Setting the Display Parameter & Intensity (dSPLY)* flow chart on page 26 to access the display menu to show the unit on the lower display.

The custom unit may also be used to enter a display tag.

Pre-defined engineering units: lb, kg, ounce, gram, ton (short), tonne (metric ton). The meter converts the reading according to the unit selected (e.g. 100.00 lb = 45.36 kg = 45359.2 g = 1600 oz).

Unit Conversions: After scaling values in the *Scale* menu have been entered during setup, automatic unit conversions are done when switching from any standard unit to any other standard unit during future changes of the *Units* menu.

Once a standard unit has been selected in the units menu, the user must then set their scaling values for that unit (under the setup menu) in order for that unit's conversion factor to take effect. Otherwise, the meter will allow the user to freely switch between standard unit selections, without applying a conversion factor.

Note that if the dual-scale feature is selected in the *Setup* menu, both PV1 and PV2 will be converted from the original standard unit to the new standard unit. A scaled PV not scaled for the selected units must be reprogrammed. *Example:* If PV 1 is scaled for pounds, and PV 2 scaled for gallons; if the *un itS* selection is changed from *Lb* to ounce, PV 2 will need to re-scaled manually back to gallons.

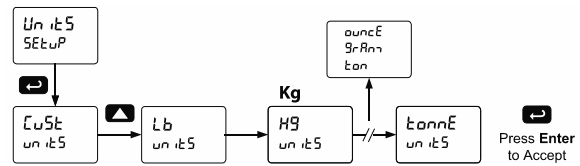

Note: PV1 and PV2 may use different standard units as starting points, however the user must select the unit and complete scaling for both PV1 and PV2 individually. For example, set PV1 equal to "Lbs" and complete the scaling for PV1 only. PV1 is now reading in Lbs. Then, change the units for PV2 to be "Kg" and complete the scaling for PV2.

Setting the Display Units or Custom Tags (Unit 5)

Enter the display unit or custom tag that will be displayed if units are selected in the Unit 5 menu, or display unit is selected as the lower display parameter. See *Setting the Display Parameter & Intensity (Display)* flow chart on page 26 to access the display menu to show the unit or tag on the lower display. The engineering units or custom legends can be set using the following 7-segment character set:

Display	Character	Display	Character
0	0	K	K
1	1	L	L
2	2	m	m
3	3	n	n
4	4	O	O
5	5	o	o
6	6	P	P
7	7	q	q
8	8	r	r
9	9	S	S
A	A	t	t
b	b	u	u
C	C	v	V
c	c	w	w
d	d	X	X
E	E	Y	Y
F	F	Z	Z
G	G	-	-
g	g	/	/
H	H	[]
h	h]	[
i	i	:	=
l	l	°	Degree(<)
J	J		Space

Notes: Degree symbol represented by (<) if programming with MeterView Pro. The letters "m" and "w" use two 7-segment LEDs each; when selected the characters to the right are shifted one position. Press and hold up arrow to auto-scroll the characters in the display.

Setting the Decimal Point (dEc Pt)

The decimal point may be set with up to five decimal places or with no decimal point at all.

Pressing the Right arrow moves the decimal point one place to the right until no decimal point is displayed, and then it moves to the leftmost position.

Pressing the Up arrow moves the decimal point to the left.

If the dual-scale feature is selected, the decimal point selections for PV1 & PV2 are enabled.

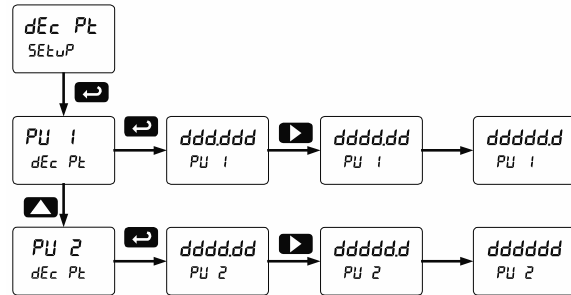

Programming the Meter (Prog)

The meter may either be scaled (SCALE) without applying an input or calibrated (CAL) by applying an input. The meter comes factory calibrated to NIST standards to read in millivolts, so for initial setup, it is recommended to use the (SCALE) function.

For strain gauge and load cell applications it is **recommended to calibrate** the meter using the sensor as the input and with ratiometric operation enabled to compensate for small variation in the excitation voltage.

The G4610 is a single input meter with dual-scale capability. If the dual-scale feature is selected in the Setup menu, the Scale 1 and Scale 2 menus are enabled for PV1 & PV2 respectively.

The process inputs may be calibrated or scaled to any display value within the range of the meter.

Program Menu for Single Scale Process

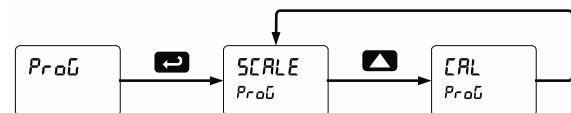

Program Menu for Dual-Scale Applications

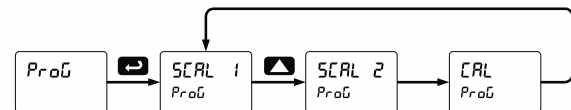

Additional parameters, not needed for most applications, are programmed in the *Advanced Features* menu. See *Advanced Features Menu* on page 36.

Calibrating the Meter with Strain Gauge/Load Cell (CAL)

To scale the meter without a signal source, refer to *Scaling the Meter (SCALE)* on page 25.

The meter can be calibrated to display the process variable in engineering units by applying the appropriate input signal and following the calibration procedure.

The use of a calibrated signal source is strongly recommended to calibrate the meter.

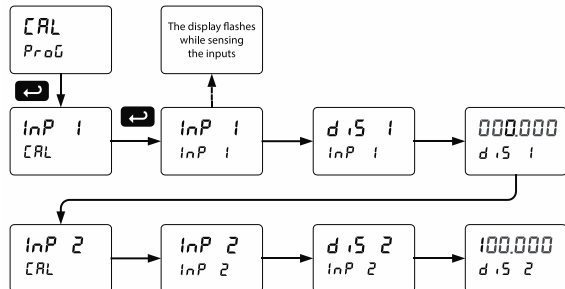

Warm up the meter for at least 15 minutes before performing calibration to ensure specified accuracy.

Multi-Point Calibration & Scaling

The meter is set up at the factory for 2-point linear calibration. The number of points for multi-point calibration/scaling is set up in the *Advanced Features* menu. Up to 32 linearization points may be selected for PV1 and up to 8 linearization points may be selected for PV2. See *Multi-Point Linearization (LINEAR)* on page 38 for details.

Scaling the Meter (SCALE)

The strain gauge input (e.g. 0-100 mV) can be scaled to display the process variable in engineering units.

A signal source is not needed to scale the meter; simply program the inputs and corresponding display values.

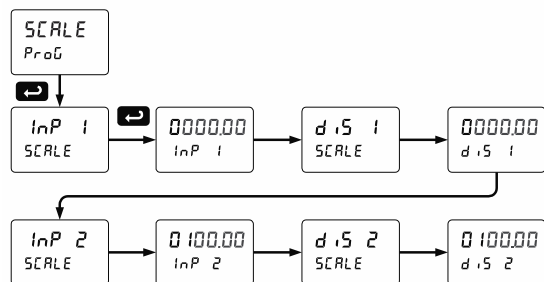

For instructions on how to program numeric values see *Setting Numeric Values* on page 22.

Dual-Scale Application

The mV input can be displayed in two different scales, by enabling the dual-scale feature in the *Setup Input* menu. See *Dual-Scale (d-5CAL)* on page 23.

To enable the dual-scale feature you must select it in the Input selection menu. See *Setting the Input Signal (InPut)* on page 23 for details.

Scaling the Input for PV1 (5CAL 1)

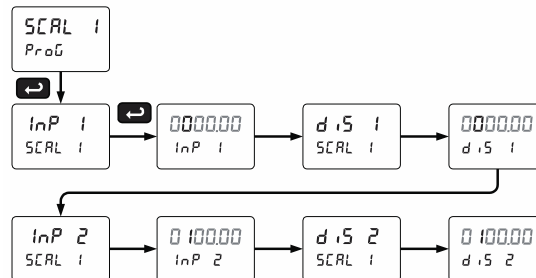

Scaling the Input for PV2 (5CAL 2)

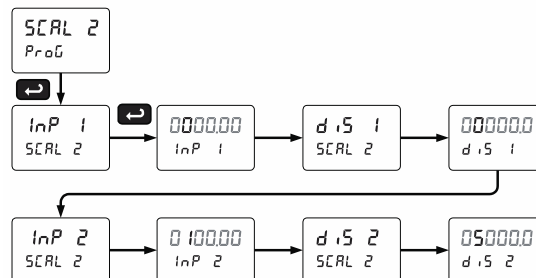

Error Message (Error)

An error message indicates that the calibration or scaling process was not successful.

After the error message is displayed, the meter reverts to input 2 during calibration or scaling and to input 1 during internal calibration, allowing the appropriate input signal to be applied or programmed.

The error message might be caused by any of the following conditions:

1. Input signal is not connected to the proper terminals or it is connected backwards.
2. Wrong signal selection in *Setup* menu.
3. Minimum input span requirements not maintained.
4. Input 1 signal inadvertently applied to calibrate input 2.

Minimum Input Span

The minimum input span is the minimum difference between input 1 and input 2 signals required to complete the calibration or scaling of the meter.

Input Range	Input 1 & Input 2 Span
15 mV	0.2 mV
25 mV, 30 mV	0.4 mV
150 mV	2.0 mV
250 mV, 300 mV	4.0 mV

Setting the Display Parameter & Intensity (dSPLeRY)

Display line 1 (L nE 1) can be programmed to display:

1. Process value 1 (PV1)
2. Process value 2 (PV2)*
3. Percent of PV1 (Pct)*
4. Relay set points
5. Toggle process value & units
6. Max & min values
7. Gross value
8. Toggle net & gross values
9. Input millivolts
10. Modbus input

Display line 2 (L nE 2) can be programmed to display:

1. Engineering units or custom legends
2. Process value 1 (PV1)
3. Process value 2 (PV2)*
4. Percent of PV1 (Pct)*
5. Relay set points
6. Toggle process value & units
7. Max & min values
8. Gross value
9. Toggle net & gross values
10. Input millivolts
11. Modbus input
12. Off (no display)

*These menu items will only appear if Dual-Scale feature is turned on.

After setting up the input and display, press the Menu button to exit programming and skip the rest of the setup menu. Press the Menu button again and the Up arrow to reach the Program menu and complete the scaling or calibration of the meter.

Display Parameter Menu

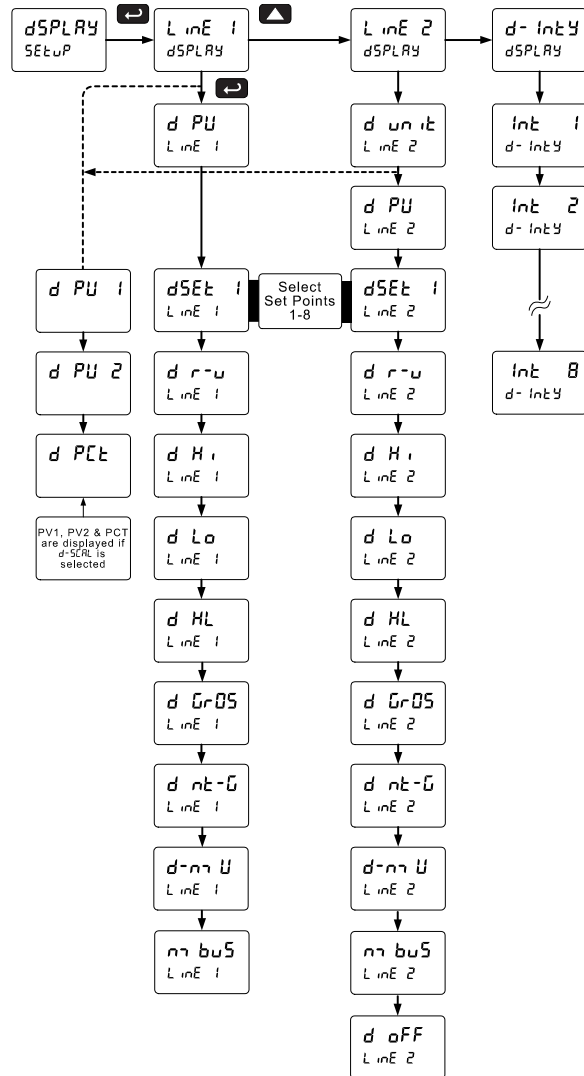

Display Intensity (d- IntY)

The meter has eight display intensity levels to give the best performance under various lighting conditions. Select intensity 8 for outdoor applications. The default intensity is 6.

Display Toggling Between Reading & Units with Tag

The G4610 can be programmed so that line 1 toggles between the reading and units and line 2 displays a tag. For instance, line 1 toggles between 9500 and Lbs and line 2 displays Tank 1.



Dual-Scale Display Feature

The dual-scale feature is of particular value in weighing applications where a second scaled display can represent the measured input in a different form (i.e. pounds & height). Both displays are independently scaled and are based on the millivolt input signal.



Setting the Relay Operation (rELAY)

This menu is used to set up the operation of the relays.

CAUTION

- During setup, the relays do not follow the input and they will remain in the state found prior to entering the Relay menu.

1. Relay action
 - a. Automatic reset only (non-latching)
 - b. Automatic + manual reset at any time (non-latching)
 - c. Latching (manual reset only)
 - d. Latching with Clear (manual reset only after alarm condition has cleared)
 - e. Pump alternation control (automatic reset only)
 - f. Sampling (the relay is activated for a user-specified time)
 - g. Off (relay state controlled by Interlock feature)
2. Set point
3. Reset point
4. Fail-safe operation
 - a. On (enabled)
 - b. Off (disabled)
5. Time delay
 - a. On delay (0-999.9 seconds)
 - b. Off delay (0-999.9 seconds)

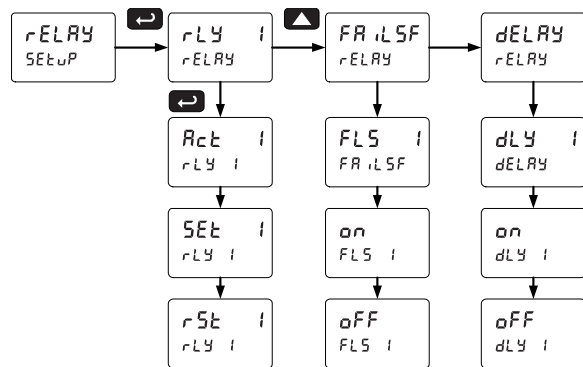

Note: The setup of relays 2-8 follows the same pattern shown here for relay 1.

Setting the Relay Action

Operation of the relays is programmed in the *Action* menu. The relays may be set up for any of the following modes of operation:

1. Automatic reset (non-latching)
2. Automatic + manual reset at any time (non-latching)
3. Latching (manual reset only, at any time)
4. Latching with Clear (manual reset only after alarm condition has cleared)
5. Pump alternation control (automatic reset only)
6. Sampling (the relay is activated for a user-specified time)
7. Off (relay state controlled by Interlock feature)

The following graphic shows relay 1 action setup; relay 2-8 are set up in a similar fashion.

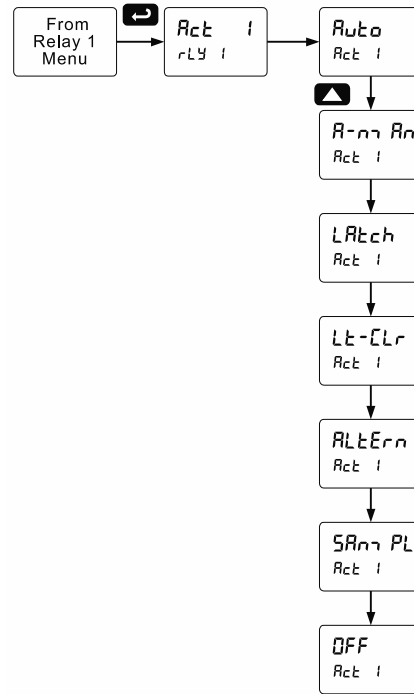

Programming Set and Reset Points

High alarm indication: program set point above reset point.

Low alarm indication: program set point below reset point.

The deadband is determined by the difference between set and reset points. Minimum deadband is one display count. If the set and reset points are programmed with the same value, the relay will reset one count below the set point.

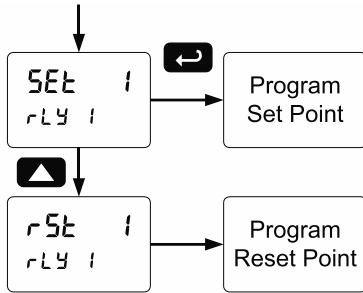

Note: Changes are not saved until the reset point has been accepted.

Setting Fail-Safe Operation

In fail-safe mode of operation, the relay coil is energized when the process variable is within safe limits and the relay coil is de-energized when the alarm condition exists. The fail-safe operation is set independently for each relay. Select **on** to enable or select **off** to disable fail-safe operation.

Programming Time Delay

The *On* and *Off* time delays may be programmed for each relay between 0 and 999.9 seconds. The relays will transfer only after the condition has been maintained for the corresponding time delay.

The *On* time delay is associated with the set point.

The *Off* time delay is associated with the reset point.

Relay and Alarm Operation Diagrams

The following graphs illustrate the operation of the relays, status LEDs, and ACK button.

High Alarm Operation (Set > Reset)

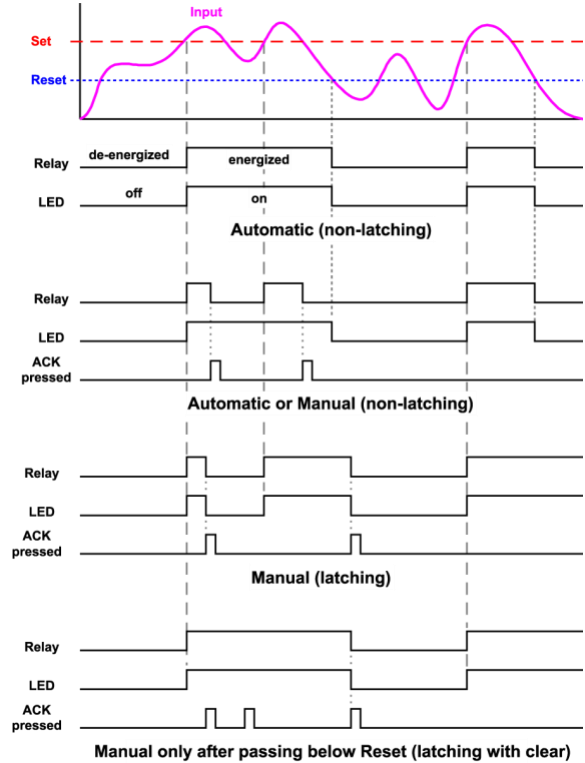

For Manual reset mode, ACK can be pressed anytime to turn "off" relay. To detect a new alarm condition, the signal must go below the set point, and then go above it.

Low Alarm Operation (Set < Reset)

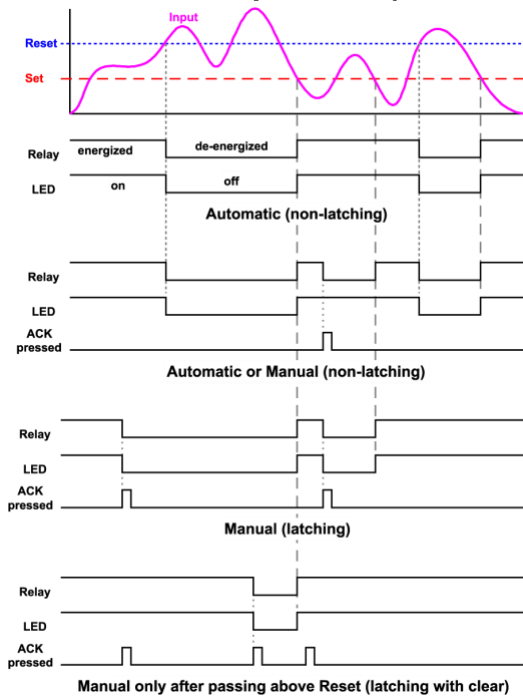

For Manual reset mode, ACK can be pressed anytime to turn "off" relay. For relay to turn back "on", signal must go above set point and then go below it.

Low Alarm with Fail-Safe Operation (Set < Reset)

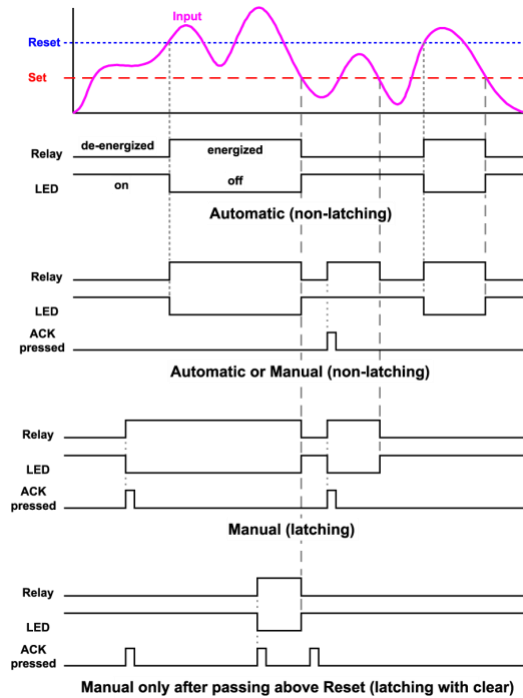

Note: Relay coil is energized in non-alarm condition. In case of power failure, relay will go to alarm state.

High Alarm with Fail-Safe Operation (Set > Reset)

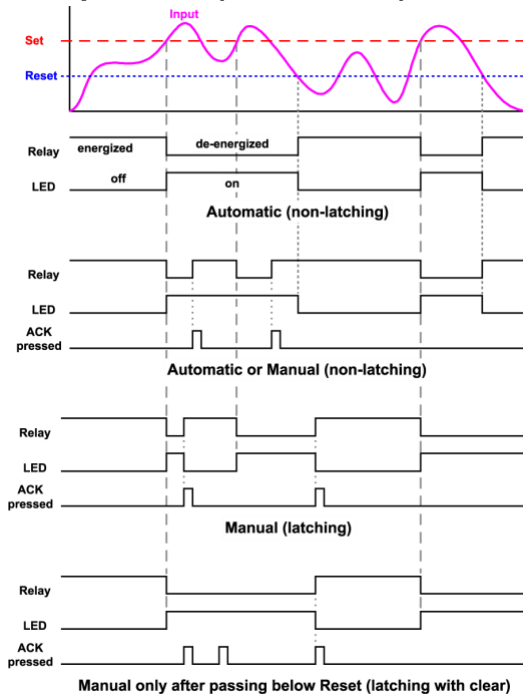

Note: Relay coil is energized in non-alarm condition. In case of power failure, relay will go to alarm state.

Time Delay Operation

The following graphs show the operation of the time delay function.

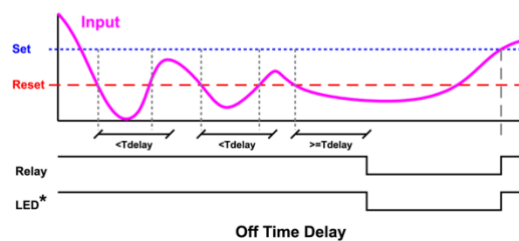
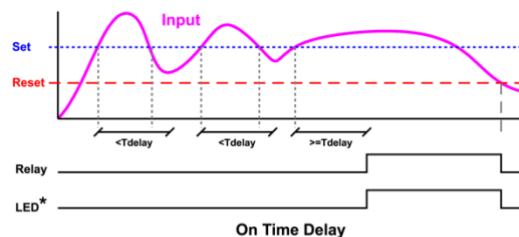

When the signal crosses the set point, the On time delay timer starts and the relay trips when the time delay has elapsed. If the signal drops below the set point (high alarm) before the time delay has elapsed, the On time delay timer resets and the relay does not change state. The same principle applies to the Off time delay.

Note: If "Automatic or Manual (A-mAn)" reset mode is selected, the LED follows the reset point and not the relay state when the relay is acknowledged.

Pump Alternation Control Operation

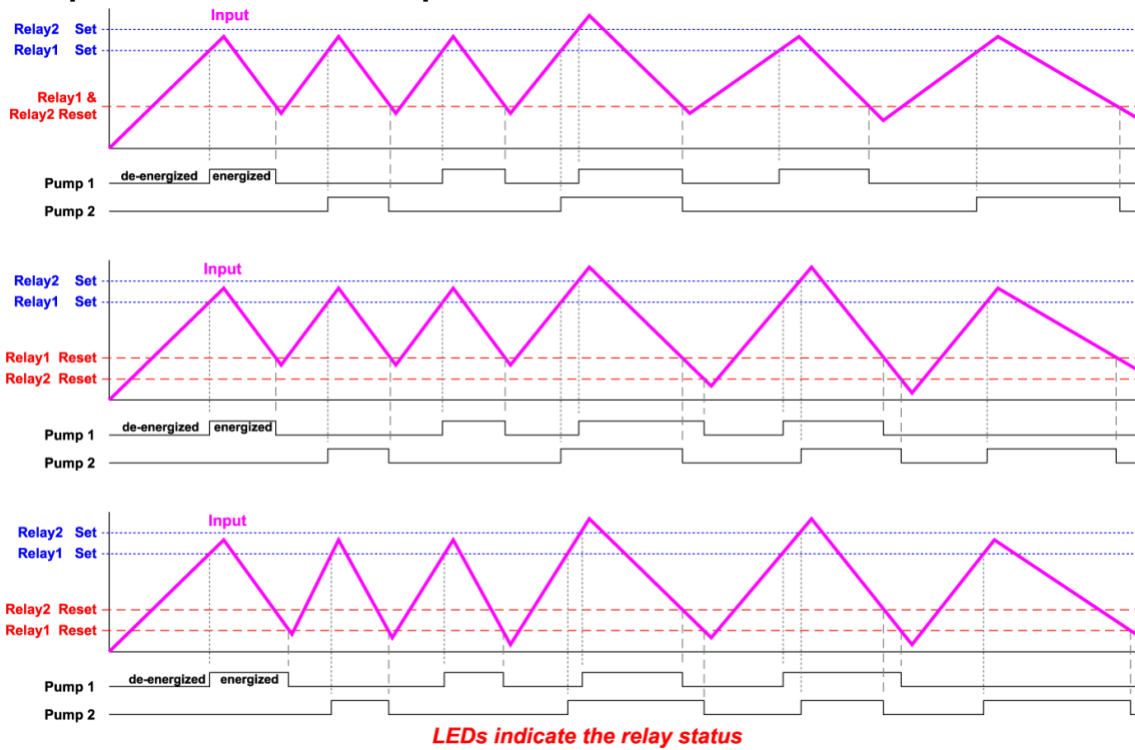

Relay Sampling Operation

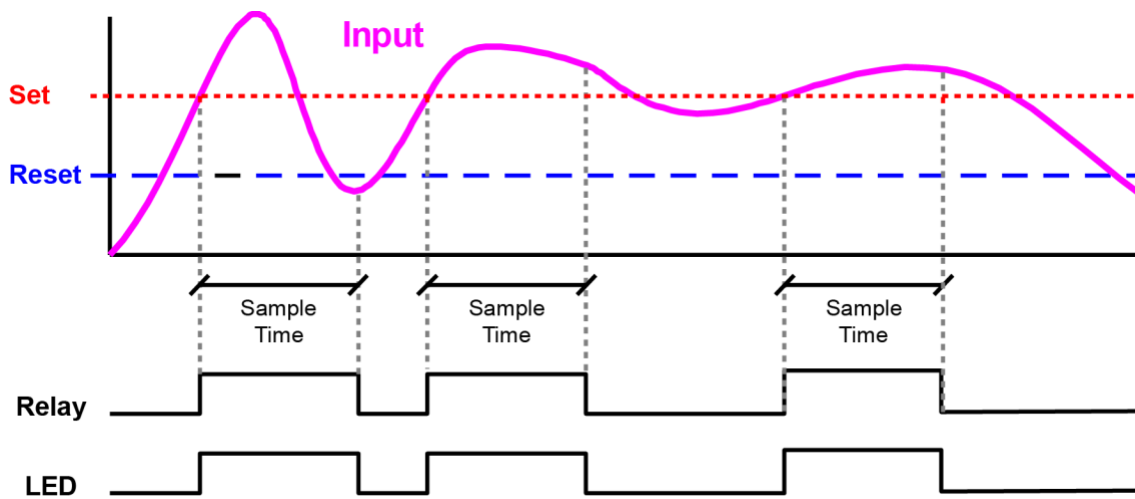

When the signal crosses the set point, the relay trips and the sample time starts. After the sample time has elapsed, the relay resets. The cycle repeats every time the set point is crossed, going up for high alarms and going down for low alarms.

The sample time can be programmed between 0.1 and 5999.9 seconds.

Relay Operation Details

Overview

The relay capabilities of the meter expand its usefulness beyond simple indication to provide users with alarm and control functions. These capabilities include front panel alarm status LEDs as well as either 2 or 4 optional internal relays and/or 4 external relays expansion module. Typical applications include high or low force, level, or pressure alarms, control applications such as simple on/off control, and relay alternation control for up to 8 pumps. There are four basic ways the relays can be used:

1. High or Low Alarms with Latching or Non-Latching Relays
2. Simple On/Off Control with 100% Adjustable Deadband
3. Sampling (Based on Time)
4. Alternation Control for up to 8 Pumps

Relays Auto Initialization

When power is applied to the meter, the front panel LEDs and alarm relays will reflect the state of the input to the meter. The following table indicates how the alarm LEDs and relays will react on power-up based on the set and reset points.

Alarm #	HI or LO Alarm	Set Point	Reset Point	Power-Up Reading	Relay & LED
1	HI	1000	500	499	Off
2	LO	700	900	499	On
3	LO	250	400	499	Off
4	HI	450	200	499	On

Fail-Safe Operation

The following table indicates how the relays behave based on the fail-safe selection for each relay:

Fail-Safe Selection	Non-Alarm State		Alarm State		Power Failure
	NO	NC	NO	NC	
Off	Open	Closed	Closed	Open	Relays go to non-alarm state
On	Closed	Open	Open	Closed	Relays go to alarm state

Note: NO = Normally Open, NC = Normally Closed. This refers to the condition of the relay contacts when the power to the meter is off.

Front Panel LEDs

The LEDs on the front panel provide status indication for the following:

LED	Status	LED	Status
1	Alarm 1	5	Alarm 5
2	Alarm 2	6	Alarm 6
3	Alarm 3	7	Alarm 7
4	Alarm 4	8	Alarm 8

The meter is supplied with four alarm points that include front panel LEDs to indicate alarm conditions. This standard feature is particularly useful for alarm applications that require visual-only indication. The LEDs are controlled by the set and reset points programmed by the user. When the display reaches a set point for a high or low alarm, the corresponding alarm LED will turn on. When the display returns to the reset point the LED will go off. The front panel LEDs respond differently for latching and non-latching relays.

For non-latching relays, the LED is always off during normal condition and always on during alarm condition, regardless of the state of the relay (e.g. Relay acknowledged after alarm condition).

For latching relays, the alarm LEDs reflect the status of the relays, regardless of the alarm condition. The following tables illustrate how the alarm LEDs function in relation to the relays and the acknowledge button (Default: F3 key assigned to ACK).

Latching and Non-Latching Relay Operation

The relays can be set up for latching (manual reset) or non-latching (automatic reset) operation.

Relay terminology for following tables	
Terminology	Relay Condition
On	Alarm (Tripped)
Off	Normal (Reset)
Ack	Acknowledged

The On and Off terminology does not refer to the status of the relay's coil, which depends on the fail-safe mode selected.

WARNING

- In latching relay mode, if Fail-Safe is off, latched relays will reset (unlatch) when power is cycled.

Non-Latching Relay (ቶህቲ)

In this application, the meter is set up for automatic reset (non-latching relay). Acknowledging the alarm while it is still present has no effect on either the LED or the relay. When the alarm finally goes away, the relay automatically resets and the LED also goes off.

Automatic reset only		
Condition	LED	Relay
Normal	Off	Off
Alarm	On	On
Ack (No effect)	On	On
Normal	Off	Off

Non-Latching Relay with Manual Reset (ቶህቲ ለሰነድ)

In this application, the meter is set up for automatic and manual reset at any time (non-latching relay). The LED and the relay automatically reset when the meter returns to the normal condition.

In addition, the relay can be manually reset while the alarm condition still exists, but the LED will stay on until the meter returns to the normal condition.

Automatic + manual reset at any time		
Condition	LED	Relay
Normal	Off	Off
Alarm	On	On
Normal	Off	Off
Next Alarm	On	On
Ack	On	Off
Normal	Off	Off

Latching Relay (ቶህቲ ለሰነድ)

In this application, the meter is set up for manual reset at any time. Acknowledging the alarm even if the alarm condition is still present resets the relay and turns off the LED.

Manual reset any time		
Condition	LED	Relay
Normal	Off	Off
Alarm	On	On
Ack	Off	Off

Latching Relay with Clear (ቶህቲ ለሰነድ)

In this application, the meter is set up for manual reset only after the signal passes the reset point (alarm condition has cleared). Acknowledging the alarm while it is still present has no effect on either the LED or the relay. When the alarm is acknowledged after it returns to the normal state, the LED and the relay go off. Notice that the LED remains on, even after the meter returns to the normal condition. This is because, for latching relays, the alarm LED reflects the status of the relay, regardless of the alarm condition.

Manual reset only after alarm condition has cleared		
Condition	LED	Relay
Normal	Off	Off
Alarm	On	On
Ack (No effect)	On	On
Normal	On	On
Ack	Off	Off

Acknowledging Relays

There are three ways to acknowledge relays programmed for manual reset:

1. Via the programmable front panel function keys F1-F3 (Example: F3 assigned to ACK).



2. Remotely via a normally open pushbutton wired to the F4 terminal at the rear of the instrument.

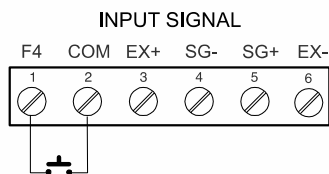

3. One of the digital inputs and the +5 V terminals on the digital I/O expansion module.

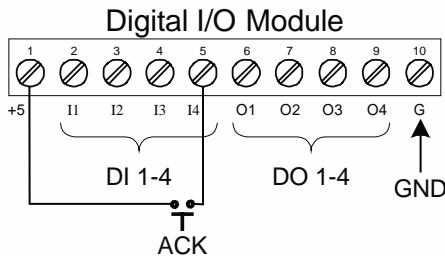

When the ACK button or the assigned digital input is closed, all relays programmed for manual reset are acknowledged.

Pump Alternation Control Applications (RL&ER)

For pump control applications where two or more similar pumps are used to control the level of a tank, it is desirable to have all the pumps operate alternately. This prevents excessive wear and overheating of one pump over the lack of use of the other pumps.

Up to 8 relays can be set up to alternate every time an on/off pump cycle is completed. The set points and reset points can be programmed, so that the first pump on is the first pump off.

Application #1: Pump Alternation Using Relays 1 & 2

1. Relays 1 and 2 are set up for pump alternation.
2. Relays 3 and 4 are set up for low and high alarm indication.

Set and Reset Point Programming			
Relay	Set Point	Reset Point	Function
1	30.000	10.000	Controls pump #1
2	35.000	5.000	Controls pump #2
3	4.000	9.000	Controls low alarm
4	40.000	29.000	Controls high alarm

Pump Alternation Operation

1. Pump #1 turns on when level reaches 30.000, when level drops below 10.000 pump #1 turns off.
2. The next time level reaches 30.000, pump #2 turns on, when level drops below 10.000 pump #2 turns off.
3. If the level doesn't reach 35.000 pump #1 and pump #2 will be operating alternately.
4. If pump #1 cannot keep the level below 35.000 pump #2 will turn on at 35.000, then as the level drops to 10.000 pump #1 turns off, pump #2 is still running and shuts off below 5.000.
5. Notice that with the set and reset points of pump #2 outside the range of pump #1, the first pump on is the first pump to go off. This is true for up to 8 alternating pumps, if setup accordingly.
6. Relay #3 will go into alarm if the level drops below 4.000 and relay #4 will go into alarm if the level exceeds 40.000.
7. Adding the 4 external relays expansion module allows using the 4 SPDT internal relays for pump alternation and the 4 SPST external relays for high, high-high, low, and low-low alarm indication.

Application #2: Pump Alternation Using Relays 3 & 4

1. Relays 1 and 2 are set up for low and high alarm indication.
2. Relays 3 and 4 are set up for pump alternation.

Set and Reset Point Programming			
Relay	Set Point	Reset Point	Function
1	495	750	Controls low alarm
2	7500	6900	Controls high alarm
3	7000	900	Controls backup pump
4	6000	1000	Controls main pump

The following graphics provide a visual representation of a typical pump alternation application with high and low alarm monitoring:

- Relay #4 turns the main pump on at 6000 pounds and turns it off at 1000 pounds.

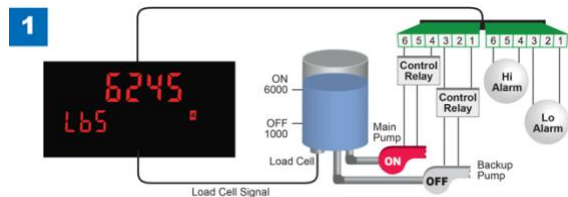

- With the Pump Alternation feature activated, the next time the level reaches 6000 pounds, relay #3 transfers and starts the backup pump.

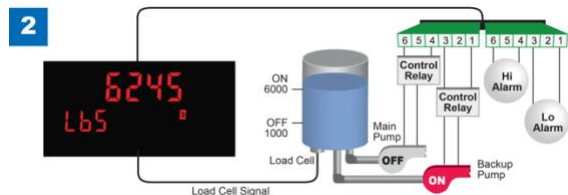

- If the backup pump is not able to keep up, and the level reaches 7000 pounds, relay #4 transfers and starts the main pump as well.

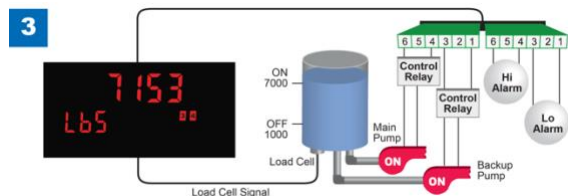

- Relay #2 trips the High Level Alarm at 7500 pounds and resets at 6900 pounds.

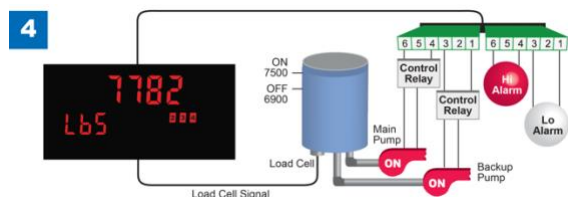

- Relay #1 trips the Low Level Alarm at 495 pounds and resets at 750 pounds.

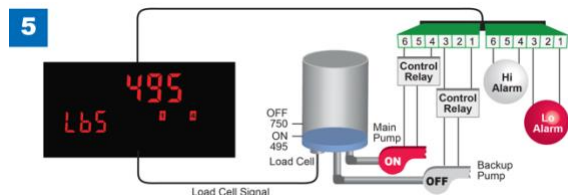

Setting Up the Interlock Relay (Force On) Feature

Relays 1-4 can be set up as interlock relays. To set up the relays for the interlock feature:

- Access the *Setup – Relay – Action* menu and set the action to off.

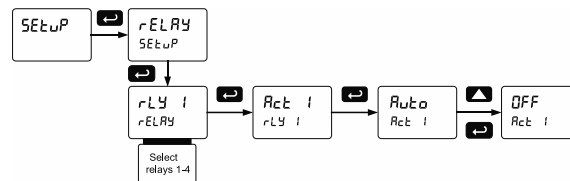

- In the *Advanced features – User* menu program any of the digital inputs to *Force On* any of the internal relays (1-4).

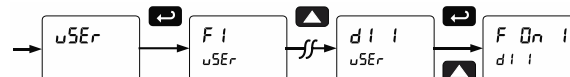

- Connect a switch or dry contact between the +5V terminal and the corresponding digital input (di-1 to di-4) terminal.

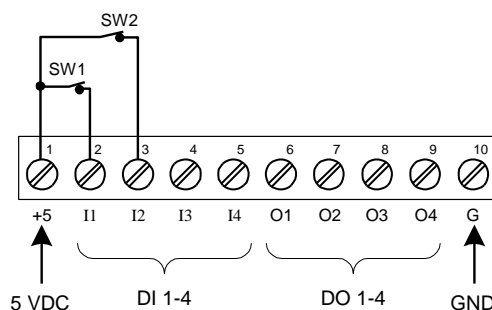

Interlock Relay Operation Example

Relays 1 & 2 are configured to energize (their front panel LEDs are steady on) when SW1 & SW2 switches (above) are closed. If the contacts to these digital inputs are opened, the corresponding front panel LEDs flash indicating this condition. The processes being controlled by the interlock relay will stop, and will re-start only after the interlock relay is re-activated by the digital inputs (switches).

Note: If multiple digital inputs are assigned to the same relay, then the corresponding logic is (AND) – i.e. both switches must be closed to activate the relay.

Scaling the 4-20 mA Analog Output (Rout)

The 4-20 mA analog output can be scaled to provide a 4-20 mA signal for any display range selected. No equipment is needed to scale the analog output; simply program the display values to the corresponding mA output signal. The *Analog Output* menu is used to program the 4-20 mA output based on display values.

For instructions on how to program numeric values see *Setting Numeric Values* on page 22.

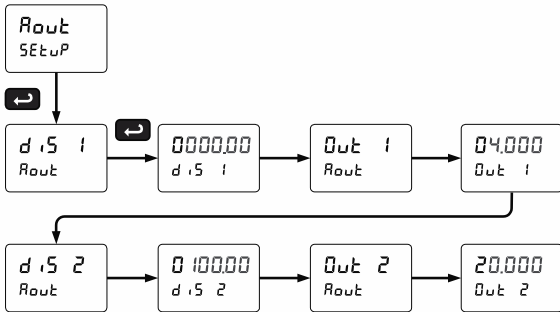

Setting Up the Password (PASS)

The *Password* menu is used for programming three levels of security to prevent unauthorized changes to the programmed parameter settings.

Pass 1: Allows use of function keys and digital inputs
 Pass 2: Allows use of function keys, digital inputs and editing set/reset points
 Pass 3: Restricts all programming, function keys, and digital inputs.

Protecting or Locking the Meter

Enter the *Password* menu and program a six-digit password. For instructions on how to program numeric values see *Setting Numeric Values* on page 22.

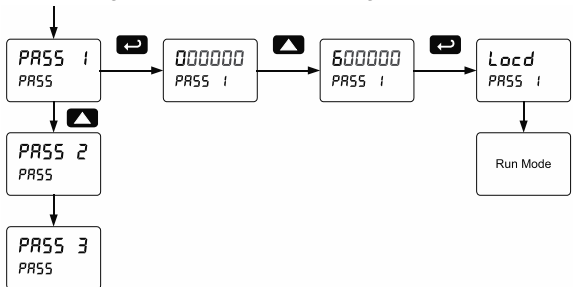

Making Changes to a Password Protected Meter

If the meter is password protected, the meter will display the message *Locd (Locked)* when the Menu button is pressed. Press the Enter button while the message is being displayed and enter the correct password to gain access to the menu. After exiting the programming mode, the meter returns to its password protected condition.

Disabling Password Protection

To disable the password protection, access the *Password* menu and enter the correct password twice, as shown below. The meter is now unprotected until a new password is entered.

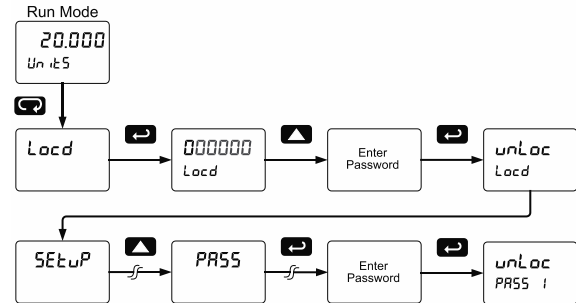

If the correct six-digit password is entered, the meter displays the message *unLoc (unlocked)* and the protection is disabled until a new password is programmed.

If the password entered is incorrect, the meter displays the message *Locd (Locked)* for about two seconds, and then it returns to Run Mode. To try again, press Enter while the *Locked* message is displayed.

Did you forget the password?

The password may be disabled by entering a master password once. If you are authorized to make changes, enter the master password 508655 to unlock the meter.

Reset Menu (rESEt)

The *Reset* menu is used to reset the tare (*r5t t r*) and the maximum or minimum readings (peak or valley) reached by the process; max & min may be reset at the same time by selecting "reset high & low" (*r5t HL*).

Note: Resetting the tare resets the max & min readings.

Tare Menu (ትዳራ)

The *Tare* menu is used to select the tare mode. There are three modes of operation: *Capture Tare*, *Programmable Tare*, and *Off*.

Capture Tare: Pressing the Tare key zeroes the display and the “T” indicator flashes indicating that tare is applied to the reading (e.g. Net weight).

Programmable Tare: Program a known value to be subtracted from the display value to obtain the net value. Pressing Reset tare clears the tare value to zero. Programmable Tare will not tare negative PVs. Use Capture Tare for negative PVs.

Off: Tare function is disabled and pressing Tare key has no effect.

Tare Functionality (ትዳራ)

The tare function zeroes out the display. In the case of scale weight, tare is used to eliminate container weight and provide net weight readings.



Manual Control Menu (ፎንትሪ)

The *Manual Control* menu is used to control the 4-20 mA analog output and the relays manually, ignoring the input. Each relay and analog output can be programmed independently for manual control. Selecting automatic control sets all relays and analog output for automatic operation.

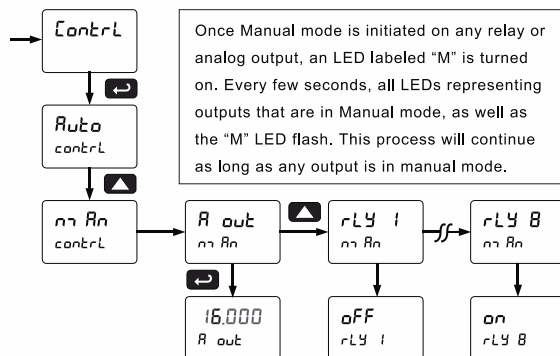

Advanced Features Menu

To simplify the setup process, functions not needed for most applications are located in the *Advanced Features* menu.

Press and hold the Menu button for three seconds to access the advanced features of the meter.

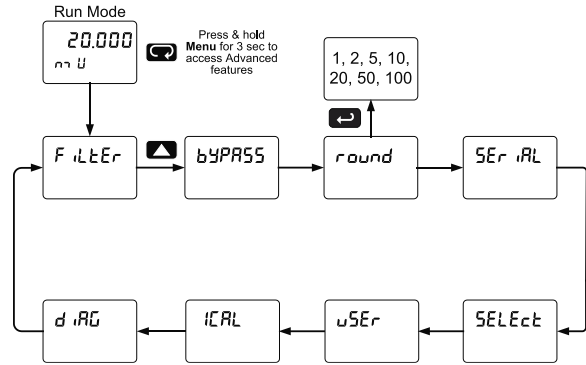

Advanced Features Menu & Display Messages

The following table shows the functions and messages of the *Advanced Features* menu in the order they appear in the menu.

Advanced Features Menu & Display Messages		
Display	Parameter	Action/Setting
F ILT Er	Filter	Set noise filter value
bYPASS	Bypass	Set filter bypass value
rOund	Rounding	Select rounding value
SERIAL	Serial	Set serial communication parameters
SLAVE ID	Slave ID	Set slave ID or meter address
baud	Baud rate	Select baud rate
tr dLY	Transmit delay	Set transmit delay for serial communication
PRr dLY	Parity	Select parity Even, Odd, or None with 1 or 2 stop bits
t-bYtE	Time byte	Set byte-to-byte timeout
SElEcT	Select	Enter the Select menu (function, cutoff, out)
FunctiOn	Input signal conditioning	Linear, select number of points
L inEAR	Linear	Set meter for linear function and select number of linearization points
PV 1	PV1	Select PV1 number of linearization points
PV 2	PV2	Select PV2 number of linearization points
no Pts	Number of points	Set PV1 for 2 to 32-point linearization Set PV2 for 2 to 8-point linearization
SCALe	Scale	Scaling parameter

Advanced Features Menu & Display Messages		
Display	Parameter	Action/Setting
5E RL 1	Scale 1	Scaling parameter 1
5E RL 2	Scale 2	Scaling parameter 2
£ u £ o F F	Cutoff	Set low-value cutoff
R u £ o 0	Auto Zero	Enter the Auto Zero function (on/off)
R o u £ P r	Analog output programming	Program analog output parameters
S o u r c E	Source	Select source for the 4-20 mA output
0 - r R n £	Overrange	Program mA output for display overrange
u - r R n £	Underrange	Program mA output for display underrange
n r R H	Maximum	Program maximum mA output allowed
n r R n	Minimum	Program minimum mA output allowed
£ R L £ b	Calibrate	Calibrate 4-20 mA output (internal reference source used for scaling the output)
4 n r R	4 mA output	Enter mA output value read by milliamp meter with at least 0.001 mA resolution
20 n r R	20 mA output	Enter mA output value read by milliamp meter with at least 0.001 mA resolution
u S E r	User I/O	Assign function keys and digital I/O
F 1	F1 function key	Assign F1 function key (*F1/F2/F3)
F 4	F4 function	Assign F4 function (digital input)
d 1 1	Digital input 1	Assign digital input 1 – 8, if expansion modules are connected
d 0 1	Digital output 1	Assign digital output 1 – 8, if expansion modules are connected
£ £ R L	Internal source calibration	Enter internal source calibration (used for scaling the meter without a signal source)
£ 5 n £ u	15 mV calibration	Calibrate 15 mV input range (internal reference source used for scaling the input)
20 n £ u	20 mV calibration	Calibrate 30 mV input range (internal reference source used for scaling the input)
£ 0 0 n £ u	100 mV calibration	Calibrate 150 mV input range (internal reference source used for scaling the input)
200 n £ u	200 mV calibration	Calibrate 300 mV input range (internal reference source used for scaling the input)
S £ r o F F	Strain offset	Calibrate the offset of the input circuit

Advanced Features Menu & Display Messages		
Display	Parameter	Action/Setting
u £ o	mV low	Calibrate low mV input (e.g. 0 mV)
u H i	mV high	Calibrate high mV input (e.g. 100 mV)
d . R £	Diagnostics	Display test and information
£ £ d £	LED test	Test all LEDs
£ n F o	Information	Display software number and version
E r R S E	Erase	Erase MeterView Pro software stored in meter's memory

Noise Filter (F £ £ £ r)

The noise filter is available for unusually noisy signals that cause an unstable process variable display. The noise filter averages the input signal over a certain period. The filter level determines the length of time over which the signal is averaged. The filter level can be set between 2 and 199. The higher the filter level, the longer the averaging time and so the longer it takes the display to settle to its final value. Setting the filter level to zero disables the filter function.

Noise Filter Bypass (b £ P R S S)

The noise filter bypass changes the behavior of the meter so that small variations in the signal are filtered out but large abrupt changes in the input signal are displayed immediately. The bypass value determines the minimum amount of signal change to be displayed immediately. All signal changes smaller than the bypass value are filtered or averaged by the meter. The noise filter bypass may be set between 0.1 and 99.9% of full scale.

Rounding Feature (r o u n d)

The rounding feature is used to give the user a steadier display with fluctuating signals. Rounding is used in addition to the filter function.

Rounding causes the display to round to the nearest value according to the rounding selected. This setting affects the last two digits, regardless of decimal point position. See examples below:

Rounding Selection	Actual Value	Display Value	Actual Value	Display Value
1	12.022	12.022	12.023	12.023
5	12.022	12.020	12.023	12.025
10	12.024	12.020	12.025	12.030

Modbus RTU Serial Communications (SEr, RL)

The meter is equipped with serial communications capability as a standard feature using Modbus RTU Serial Communication Protocol.

The meter may be connected to a PC for initial configuration via the onboard micro USB connection. For ongoing digital communications with a computer or other data terminal equipment, an RS-232, or RS-485 option is required; see *Ordering Information* on page 6 for details.

CAUTION

- **DO NOT** connect any equipment other than Group Four's expansion modules, cables, or meters to the RJ45 M LINK connector. Otherwise damage will occur to the equipment and the meter.

Note: More detailed instructions are provided with each optional serial communications adapter.
Note: Refer to the G4610 Modbus Register Tables located at www.groupfourtransducers.com for details.

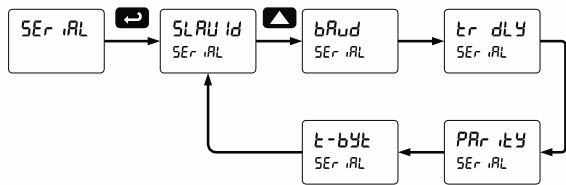

When using more than one meter in a multi-drop mode, each meter must be provided with its own unique address. The meter address (Slave ID) may be programmed between 1 and 247. The transmit delay may be set between 0 and 199 ms. The parity can be set to even, odd, or none with 1 or 2 stop bits.

Select Menu (SELEct)

The *Select* menu is used to select the input signal conditioner applied to the input (linear), low-value cutoff, Auto-zero, and analog output programming. The multi-point linearization is part of the linear function selection.

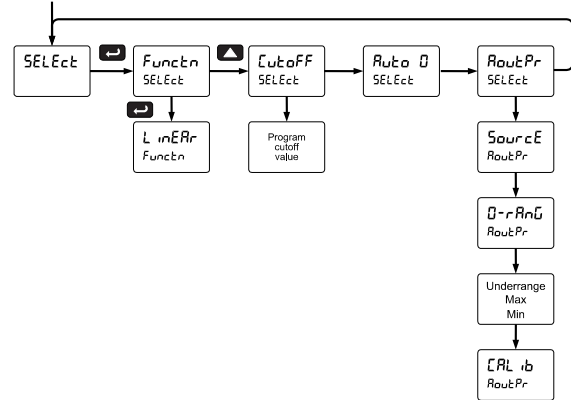

Input Signal Conditioning (FunctiOn)

The *Function* menu is used to select the input signal conditioner applied to the input: linear. The multi-point linearization is part of the linear function selection. Meters are set up at the factory for linear function with 2-point linearization. The linear function provides a display that is linear with respect to the input signal.

Multi-Point Linearization (L inERr)

Meters are set up at the factory for linear function with 2-point linearization. Up to 32 linearization points can be selected for PV under the linear function. The multi-point linearization can be used to linearize the display for non-linear signals. If the dual-scale Level feature has been selected, the menus for PV1 & PV2 are enabled. PV2 can be programmed with up to 8 linearization points.

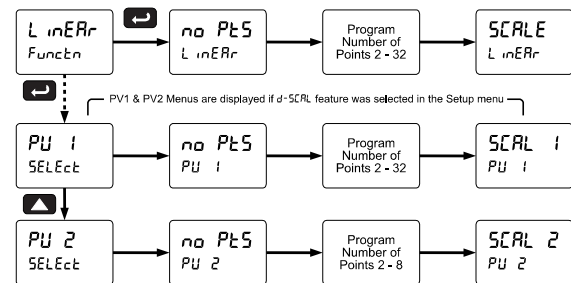

Auto-Zero (Auto 0)

Auto-zero corrects for drift that can occur over time that causes the input signal to slowly change. The meter will continue to read zero despite slow and small changes to the input signal. The auto-zero value represents the percent of full scale drift that the meter will correct.

Under normal circumstances, when the signal increases quickly, by an amount greater than the auto-zero percent of full scale, the value will not be adjusted for. Slow signal changes that occur over time at increments less than the auto-zero value, will not register on the meter (example: dust on a load cell or sensor drift over time).

Low-Value Cutoff (LowFF)

The low-value cutoff feature allows the meter to be programmed so that below a certain value, the meter always displays zero.

The cutoff value may be programmed from 0 to 999999. The meter will display zero below the cutoff value. Programming the cutoff value to zero disables the cutoff feature.

Analog Output Programming (OutPr)

The *Analog Output Programming* menu is used to program the behavior of the 4-20 mA output. The following parameters and functions are programmed in this menu:

1. Source: Source for generating the 4-20 mA output (e.g. PV)
2. Overrange: Analog output value with display in overrange condition
3. Underrange: Analog output value with display in underrange condition
4. Max: Maximum analog output value allowed regardless of input
5. Min: Minimum analog output value allowed regardless of input
6. Calibrate: Calibrate the internal 4-20 mA source reference used to scale the 4-20 mA output

Analog Output Source

The source for generating the 4-20 mA output may be assigned to the process variable, maximum or minimum value reached by the process, one of the set points, or the Modbus PV input.

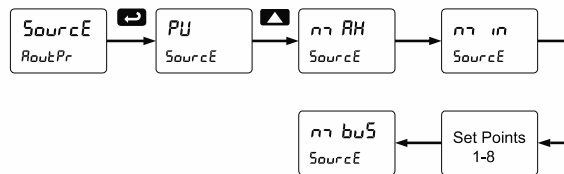

Analog Output Calibration

To perform the analog output calibration, it is recommended to use a milliamp meter with a resolution of at least 0.1 μ A to measure the output current. The values saved internally during this procedure are used for scaling the 4-20 mA output in the *Setup* menu.

Analog Output Calibration Procedure

1. Wire the G4610 4-20 mA output to a current loop that includes a power supply (internal or external 12 to 24 VDC), and the mA input on the digital meter. See *Figure 23. 4-20 mA Output Connections* on page 17 for details.
2. Turn on all devices. Allow for a 15 to 30 minute warm-up.
3. Go to the Advanced Features menu, and navigate to the Analog Output Programming (OutPr)/Calibration (CAL 0) menu and press **Enter**.
4. The display will show 4 mAR. The G4610 mA output should now be close to 4 mA. Press **Enter** and the display will show 04.000. Enter the actual value read by the digital mA meter and press **Enter**.
5. The display will show 20 mAR. The G4610 mA output should now be close to 20 mA. Press **Enter** and the display will show 20.000. Enter the actual value read by the digital mA meter and press **Enter**.
6. The meter will now calculate the calibration factors and store them.
7. Press **Menu** to exit and return to Run mode.

Programmable Function Keys User Menu (μSEr)

The *User* menu allows the user to assign the front panel function keys F1, F2, and F3, the digital input F4 (a digital input located on the input signal connector), and up to eight additional digital inputs to access most of the menus or to activate certain functions immediately (e.g. reset max & min, hold relay states, etc.). This allows the meter to be greatly customized for use in specialized applications.

Up to eight digital outputs can be assigned to a number of actions and functions executed by the meter (i.e. alarms, relay acknowledgement, reset max, min, or max & min, tare, and reset tare). The digital outputs can be used to trigger external alarms or lights to indicate these specific events.

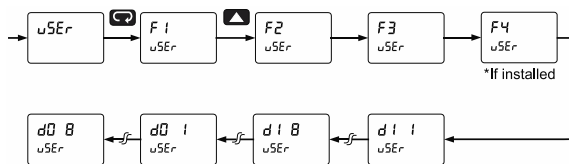

Function Keys & Digital I/O Available Settings

Refer to the following table for descriptions of each available function key or digital I/O setting.

Function Keys & Digital I/O Available Settings	
Display	Description
rSt H	Reset the stored maximum display value
rSt Lo	Reset the stored minimum display value
rSt HL	Reset the stored maximum & minimum display values
tRrE	Capture tare and zero the display
rSt tr	Reset captured tare and resume normal operation
rELRY	Directly access the relay menu
SEt i*	Directly access the set point menu for relay 1 (*through 8)
rLY d	Disable all relays until a button assigned to <i>enable relays (rLY E)</i> is pressed
rLY E	Enable all relays to function as they have been programmed
H HoLd	Hold current relay states and analog output as they are until a button assigned to <i>enable relays (rLY E)</i> is pressed
d HoLd	Hold the current display value, relay states, and analog output momentarily while the function key or digital input is active. The process value will continue to be calculated in the background.
Ln i H	Display maximum display value on line 1
Ln i Lo	Display minimum display value on line 1

Function Keys & Digital I/O Available Settings	
Display	Description
Ln i HL	Display maximum & minimum display values on line 1
Ln2 n rU	Display the mV input on line 2
Ln2 H	Display maximum display value on line 2
Ln2 Lo	Display minimum display value on line 2
Ln2 HL	Display maximum & minimum display values on line 2
ZEr o	Zero the display (this is different from <i>capture tare</i> because it cannot be reset)
F On i*	Force relay 1 (*through 4) into the on state. This function is used in conjunction with a digital input expansion module to achieve interlock functionality. See <i>Setting Up the Interlock Relay (Force On) Feature</i> on page 34 for details about interlock relays.
EnterL	Directly access the <i>Manual Control</i> menu
d,SRbL	Disable the selected function key or digital I/O
RcH	Acknowledge all active relays that are in a manual operation mode such as auto-manual or latching
rESEt	Directly access the reset menu
n rEnu	Mimic the menu button functionality (digital inputs only)
r rUHL	Mimic the right arrow/F1 button functionality (digital inputs only)
uP	Mimic the up arrow/F2 button functionality (digital inputs only)
EnEr	Mimic the enter/F3 button functionality (digital inputs only)
RLn r i*	Provide indication when alarm 1 (*through 8) has been triggered (digital outputs only)

Internal Source Calibration (CAL)

There is **no need to recalibrate** the meter when first received from the factory.

The meter is **factory calibrated** prior to shipment for millivolts with calibration equipment that is certified to NIST standards.

The internal source allows the user to scale the meter without applying a signal.

The use of calibrated signal sources is necessary to perform the internal source calibration of the meter.

Check calibration of the meter at least every 12 months. Each range must be recalibrated separately.

Notes:

1. *mV input: If meter is in operation and it is intended to accept only one input range (e.g. 0-30 mV), recalibration of other ranges is not necessary.*
2. *Strain gauge: If the meter is intended to accept a strain gauge bridge input, it is recommended to use the CAL function with ratiometric compensation turned on.*
3. *Allow the meter to warm up for at least 15 minutes before performing the internal source calibration procedure.*

The *Internal calibration* menu is part of the *Advanced Features* menu.

1. Press and hold the Menu button for three seconds to access the advanced features of the meter.
2. Press the Up arrow button to scroll to the *Internal calibration* menu (CAL) and press Enter.
3. The meter displays the first input range (15 mV), press the Up arrow to select any other range (e.g. 250 mV). Press Enter to start the calibration process.

Example of Internal Calibration for 100 mV input range:

4. The meter displays the message "Stroff" (strain offset), short the SG+, SG- terminals and press Enter. The *low* input message is displayed (U Lo). Apply the low input signal (e.g. 0.00 mV) and press Enter. The display flashes for a moment while the meter is accepting the low input signal.
5. After the display stops flashing, a number is displayed with the leftmost digit brighter than the rest. The bright digit is the active digit that can be changed by pressing the Up arrow button. Press the Right arrow button to move to the next digit.
6. Set the display value to correspond to the input signal being calibrated; typically 0.00 mV.
7. The display moves to the *high* input calibration (U Hi). Apply the high input signal and press Enter.
8. Set the display for the high input calibration, in the same way as it was set for the low input calibration, typically 100.00 mV.

The following graphic shows the calibration of the 100 mV input range. The other ranges are calibrated in a similar way.

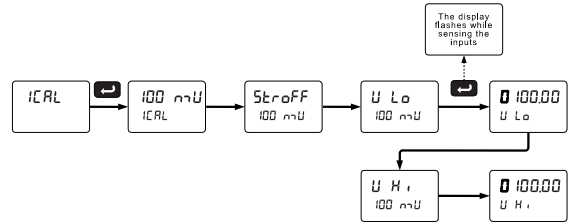

Tips:

- Low and high input signals can be any valid values within the range of the meter.
- Observe minimum input span requirements between input 1 and input 2.
- Low input should be less than high input signal.

Error Message (Error)

An error message indicates that the calibration or scaling process was not successful.

After the error message is displayed, the meter reverts to input 2 during calibration or scaling and to input 1 during internal calibration, allowing the appropriate input signal to be applied or programmed.

The error message might be caused by any of the following conditions:

1. Input signal is not connected to the proper terminals, or it is connected backwards.
2. Wrong signal selection in *Setup* menu.
3. Minimum input span requirements not maintained.

Minimum Input Span

The minimum input span is the minimum difference between input 1 and input 2 signals required to complete the calibration or scaling of the meter.

Input Range	Input 1 & Input 2 Span
15 mV	0.2 mV
25 mV, 30 mV	0.4 mV
150 mV	2.0 mV
250 mV, 300 mV	4.0 mV

Meter Operation

The meter is capable of accepting any signal from -250 to 250 mV in bipolar mode, or 0 to 300 mV in unipolar mode, and displaying these signals in engineering units from -99999 to 999999 (e.g. a 0-100 mV signal could be displayed as 0 to 50000). The dual-line display can be customized by the user to operate in such a way as to satisfy a specific application. Typically, display line 1 is used for the process variable; while line 2 is used for engineering units, custom legend, or set point indication.

The input signal can be scaled to display the process in two different scales; for example, line 1 could indicate weight in pounds and line 2 could indicate percent of maximum weight capacity. The meter can also be set up to display the mV input on line 1 and the Modbus input on line 2. The relays and analog output can be programmed to operate from the Modbus PV input if the Modbus input has been assigned to display line 1.

During operation, the meter can be either tared or zeroed. The tare feature is useful for momentarily zeroing out of the display, in the case where there is additional weight than what is intended to be measured (e.g. a bucket on the scale is being filled with material). The meter will display a T to indicate that the display has been tared and taring is resettable via the reset tare operation. The zero feature is useful for permanent zeroing of the meter, in the case where there has been drift in the strain gauge output over time. The zero feature will zero out the display without indication or the ability to reset.

Front Panel Buttons Operation

Button Symbol	Description
	Press to enter or exit <i>Programming Mode</i> .
	Press to zero the meter or other parameter/ function assigned through the <i>User</i> menu.
	Press to reset tare or other parameter/function assigned through the <i>User</i> menu.
	Press to tare the display value or other parameters/function assigned through the <i>User</i> menu.

Function Keys Operation

During operation, the programmable function keys operate according to the way they have been programmed in the *Advanced Features – User* menu. See *Programmable Function Keys User Menu (u5Er)* on page 40 for details.

The table above shows the factory default settings for F1, F2, and F3.

F4 Operation

A digital input, F4, is standard on the meter. This digital input is programmed identically to function keys F1, F2, and F3. The input is triggered with a contact closure to COM, or with an active low signal. During operation, F4 operates according to the way it has been programmed in the *Advanced Features – User* menu. See *Programmable Function Keys User Menu (u5Er)* on page 40 for details.

Maximum/Minimum Readings

The max & min readings (peak & valley) reached by the process can be displayed either continuously or momentary:

1. Display briefly by assigning to the F1-F3 function keys or to the digital inputs in the *User* menu. Any of the F1-F3 function keys (buttons) and the digital inputs can be programmed to reset the max & min readings.
2. Display continuously by assigning either display to max/min through the *Display* menu.

To display max reading using function key:

1. Press user assigned function key/digital input to display maximum reading since the last reset/power-up.
2. To reset max/min, press the Menu button, then the Up arrow/F2 button until the Reset (r 55E) menu is displayed.
3. Press the Up arrow/F2 button to select reset high (r 5E H i), reset low (r 5E L a), or reset high and low (r 5E H L) is displayed and then press the Enter/F3 button. The max and/or min displays are reset to actual values.
4. Press Menu to exit max/min display reading.

To display max/min readings continuously:

Assign either display to Max (d H i), Min (d L a), or toggle between Max and Min (d H L) every 10 seconds.

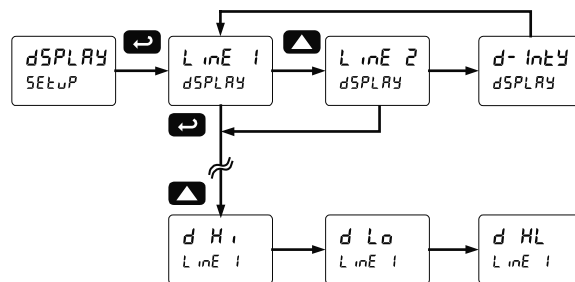

Troubleshooting

Due to the many features and functions of the meter, it's possible that the setup of the meter does not agree with what an operator expects to see. If the meter is not working as expected, refer to the *Diagnostics* menu and consult the recommendations described below.

Diagnostics Menu (d ,RG)

The *Diagnostics* menu is located in the *Advanced Features* menu, to access *Diagnostics* menu see *Advanced Features Menu* on page 36.

This menu allows the user to test the functionality of all the meter LEDs, check the meter's software and version information, and erase the MeterView Pro software installation files from the meter. Press the Enter button to view the settings and the Menu button to exit at any time.

For a description of the diagnostic messages, see *Advanced Features Menu & Display Messages* on page 36.

Determining Software Version

To determine the software version of a meter:

1. Go to the *Diagnostics* menu (d ,RG) and press Enter button.
2. Press Up arrow button and scroll to Information menu (InFa).
3. Press Enter to access the software number (5Ft) and version (UER) information. Write down the information as it is displayed. Continue pressing Enter until all the information is displayed.
4. The meter returns to Run Mode after displaying all the settings.

Reset Meter to Factory Defaults

When the parameters have been changed in a way that is difficult to determine what's happening, it might be better to start the setup process from the factory defaults.

Instructions to load factory defaults:

1. Enter the *Advanced Features* menu. See *Advanced Features Menu* on page 36.
2. Press Up arrow to go to *Diagnostics* menu
3. Press and hold Right arrow for three seconds, press Enter when display flashes rESEt .
Note: If Enter is not pressed within three seconds, the display returns to the *Diagnostics* menu.
4. The meter goes through an initialization sequence (similar as on power-up), and loads the factory default settings.

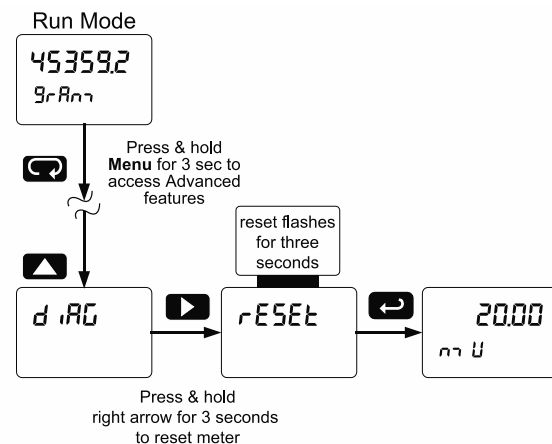

Factory Defaults & User Settings

The following table shows the factory setting for most of the programmable parameters on the meter.

Parameter	Display	Default Setting
Input type	POLAR	Polar = Uni
Input Range	RRnE	Range = 30mV
Ratiometric	RtIo	Ratio = Yes
Dual-scale	d-5RL	No (Single scale)
Filter	F.LtEr	70
Bypass	bYPR55	0.2
Rounding	round	1
Function	Function	Linear
Number of points	no Pts	2
Programming	PRoG	Scale
Input 1	INP 1	0.00 mV
Display 1	d15 1	0.00
Input 2	INP 2	100.00 mV
Display 2	d15 2	100.00
Decimal point	dddddd	3 places
Cutoff value	Cutoff	0.000 (disabled)
Auto-zero	RtZo	0.05% of Full Scale
Display assignment	d5PLRY	
Line 1	Line 1	PV: Process variable
Line 2	Line 2	Eng units: mV
Display intensity	d-intY	8
Relay 1 action	Rct 1	Automatic
Relay 1 set point	SEt 1	10.00
Relay 1 reset point	r5t 1	5.00
Relay 2 action	Rct 2	Automatic
Relay 2 set point	SEt 2	20.00
Relay 2 reset point	r5t 2	15.00
Relay 3 action	Rct 3	Automatic
Relay 3 set point	SEt 3	30.00
Relay 3 reset point	r5t 3	25.00
Relay 4 action	Rct 4	Automatic
Relay 4 set point	SEt 4	40.00
Relay 4 reset point	r5t 4	35.00
Fail-safe relay 1	FLS 1	Off
Fail-safe relay 2	FLS 2	Off
Fail-safe relay 3	FLS 3	Off
Fail-safe relay 4	FLS 4	Off

Parameter	Display	Default Setting
On delay relay 1	On 1	0.0 sec
Off delay relay 1	OFF 1	0.0 sec
On delay relay 2	On 2	0.0 sec
Off delay relay 2	OFF 2	0.0 sec
On delay relay 3	On 3	0.0 sec
Off delay relay 3	OFF 3	0.0 sec
On delay relay 4	On 4	0.0 sec
Off delay relay 4	OFF 4	0.0 sec
Display 1 analog out	d15 1	0.00
Output 1 value	Out 1	4.000 mA
Display 2 analog out	d15 2	100.00
Output 2 value	Out 2	20.000 mA
Source analog output	Source	Process Variable
Overrange output	OverRange	21.000 mA
Underrange output	UnderRange	3.000 mA
Maximum output	max	23.000 mA
Minimum output	min	1.000 mA
Slave ID (Address)	SLRuid	247
Baud rate	baud	9600
Transmit delay	tr dly	10 ms
Parity	PRrity	Even
Byte-to-byte timeout	t-byt	010 (0.1 sec)
F1 function key	F1	Zero
F2 function key	F2	Reset Tare
F3 function key	F3	Tare
F4 Function	F4	Acknowledge relays
Digital input 1	d1 1	Menu
Digital input 2	d1 2	Right arrow/F1
Digital input 3	d1 3	Up arrow/F2
Digital input 4	d1 4	Enter/F3
Digital output 1	d0 1	Alarm 1
Digital output 2	d0 2	Alarm 2
Digital output 3	d0 3	Alarm 3
Digital output 4	d0 4	Alarm 4
Password 1	PR55 1	000000 (unlocked)
Password 2	PR55 2	000000 (unlocked)
Password 3	PR55 3	000000 (unlocked)

Troubleshooting Tips

This meter is a highly sophisticated instrument with an extensive list of features and capabilities. If the front panel buttons are used to program the meter, it may be a difficult task to keep everything straight. That is why we strongly recommend the use of the free MeterView Pro software for all programming activities. A cable is provided with the meter for programming with MeterView Pro software.

If you have programmed the meter with the front panel buttons and it is not working as intended, try re-programming the meter using MeterView Pro software.

Symptom	Check/Action
No display at all	Check power at power connector
Not able to change setup or programming, LoCd is displayed	Meter is password-protected, enter correct six-digit password to unlock
Meter does not respond to input change	If a <i>Low Value Cutoff</i> has been programmed, the meter will display zero below that point, regardless of the input – which can appear like the meter is not responding to an input change. Check to make sure the problem is not being caused by an undesired low value flow cutoff value.
Meter displays error message during calibration (Error)	Check: 1. Signal connections 2. Input selected in <i>Setup</i> menu 3. Minimum input span requirements
Meter displays 1. 999999 2. -999999 3. FRULt	Check: 1. Input selected in <i>Setup</i> menu 2. Signal at Signal connector 3. Input exceeds range selected
Display is unstable	Check: 1. Input signal stability and value 2. Display scaling vs. input signal 3. Filter and bypass values (increase) 4. Increase Rounding value
Display response is too slow	Check filter and bypass values
Display reading is not accurate	Check: 1. Input signal conditioner selected: Linear, square root, etc. 2. Scaling or calibration
Display does not respond to input changes, reading a fixed number	Check: 1. Display assignment, it might be displaying max, min, or set point.
Display alternates between 1. H and a number 2. Lo and a number	Press Menu to exit max/min display readings.
Relay operation is reversed	Check: 1. Fail-safe in <i>Setup</i> menu 2. Wiring of relay contacts
Relay and status LED do not respond to signal	Check: 1. Relay action in <i>Setup</i> menu 2. Set and reset points
Flashing relay status LEDs	Relays in manual control mode or relay interlock switches opened.
Meter not communicating with application programs	Check: 1. Serial adapter and cable 2. Serial settings 3. Meter address and baud rate
If the display locks up or the meter does not respond at all	Cycle the power to reboot the microprocessor.
Other symptoms not described above	Call Technical Support for assistance.

Note: Certain sequences of events can cause unexpected results. To solve these issues, it is best to start fresh from factory defaults and use the manual as a step by step programming guide, rather than a random approach to programming. To reset the meter to factory defaults, see Reset Meter to Factory Defaults on page 43. In addition, for best results, we recommend using the free MeterView Pro software for all programming needs.



EU Declaration of Conformity

Issued in accordance with ISO/IEC 17050-1:2004.

We,

**Group Four Transducers Inc
22 Deer Park Drive
E Longmeadow, MA 01028 USA**

as the manufacturer, declare under our sole responsibility that the product(s),

Model G4610 Series Strain Gauge Meter

to which this declaration relates, is in conformity with the European Union Directives shown below:

2014/35/EU	Low Voltage Directive
2014/30/EU	EMC Directive
2011/65/EU	RoHS Directive

This conformity is based on compliance with the application of harmonized or applicable technical standards and, when applicable or required, a European Union notified body certification.

Standards:

EN 55022:2003
EN 61000-6-2:2001
EN 61010-1:2001
EN 61326:2006

The standards EN 55022:2003, EN 61000-6-2:2001, EN 61010-1:2001, and EN 61326:2006 are no longer harmonized. The requirements of these standards have been checked against the harmonized standards EN 55022:2010, EN 61000-6-2:2005, EN 61010-1:2010, and EN 61326:2013 and there were no major technical changes affecting the latest technical knowledge for the products listed above.

Product Markings: 

Signed for and on behalf of Group Four Transducers Inc:



Name: Peter Skowronski
Company: Group Four Transducers Inc
Title: Applications Engineer
Date: 07/28/2020

Document No: DoC PD6100GT {072820}



Group Four Transducers

22 Deer Park Drive,
E Longmeadow, MA 01028
www.groupfourtransducers.com

Phone : **(800) 419 1444**
Fax : (413) 525 -6182
sales@group-4.com