

The OMSH is a Stainless Steel self centering rocker column compression load cell ideal for fertilizer and seed weighing systems, mixers, silos, truck scales, tank weighing applications. The hermetically sealed load cell is ideal for use in heavy wash down applications. Protection class IP69K.



FEATURES

- Capacities in tons 20,30,40 & 50T
- Capacities in KLBS 30 & 60 Klbs
- Stainless Steel construction
- Anti-rotation ring for movement protection
- Environmental Protection IP69 with hermetic sealing
- 5-position receptacle red connector

APPLICATIONS

- Mixers
- Tank weighing
- Truck scales
- Hopper weighing
- Silo weighing
- Wash down applications

DIMENSIONS

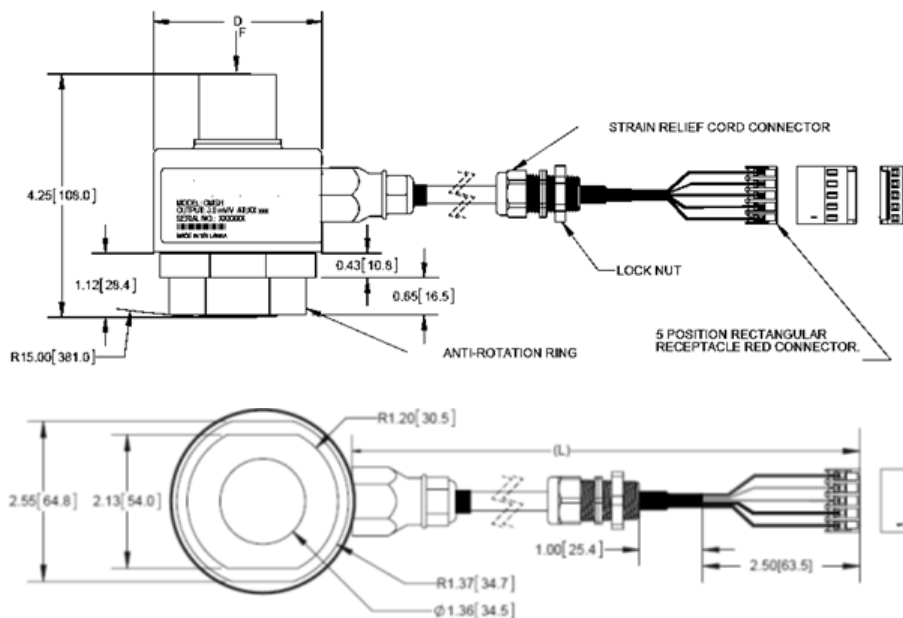

CAPACITY (ton/klb)	D inches (mm)
20t	2.91 (74.0)
30t	2.91 (74.0)
40t	2.91 (74.0)
50t	2.91 (74.0)
30klb	2.91 (74.0)
60klb	2.91 (74.0)

SPECIFICATIONS

Model	OMSH	
Capacities	Ton	20, 30, 40, 50
	KLBS	30, 60
Full Scale Output (FS)	mV/V	3.0± 0.1%
Calibration in MV/V/Ω	%	≤±0.05
Non-Linearity	%FS	≤±0.03
Hysteresis	%FS	≤±0.05
Creep @30min	%FS	≤±0.02
Zero Balance	%FS	≤±1
Temperature Effect (output)	%FS/10C	≤±0.01
Temperature Effect (zero)	%FS/10C	≤±0.02
Temperature Range (compensated)	C	-10... +40
Temperature Range (operating)	C	-40... +65
Terminal Resistance (input)	Ω	386±50
Terminal Resistance (output)	Ω	350±5
Excitation Voltage	VDC	5...15
Insulation Resistance @50VDC	MΩ	>5000
Safe Overload Limit	%FS	130
Ultimate Load	%FS	200
Cable Length	Meter	9
Cable Type	22 AWG 4 Conductor AL Foil Shielded PVC Black cable with drain wire	
Seal Type	IP69	
Element Material	Stainless Steel	

WIRING

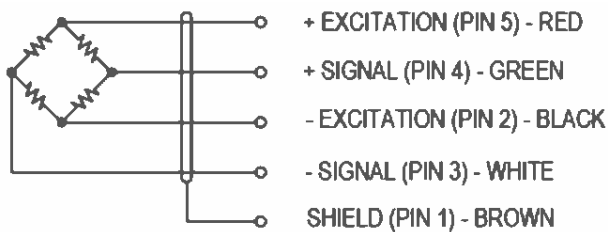

PART NUMBER

CAPACITY (ton/klb)	D inches (mm)	G4 PART NUMBER
20t	2.91 (74.0)	5031-001-00
30t	2.91 (74.0)	5031-000-00
40t	2.91 (74.0)	5031-002-00
50t	2.91 (74.0)	5031-003-00
30klb	2.91 (74.0)	5031-004-00
60klb	2.91 (74.0)	5031-005-00

10.29.20