

The SBL is a compression ring button load cell, ideal for force measurement in small spaces.



FEATURES

- Capacity: 15klbs
- Stainless steel construction
- Environmental protection IP67
- Low profile design

APPLICATIONS

- Force measurement

OUTLINE DIMENSIONS

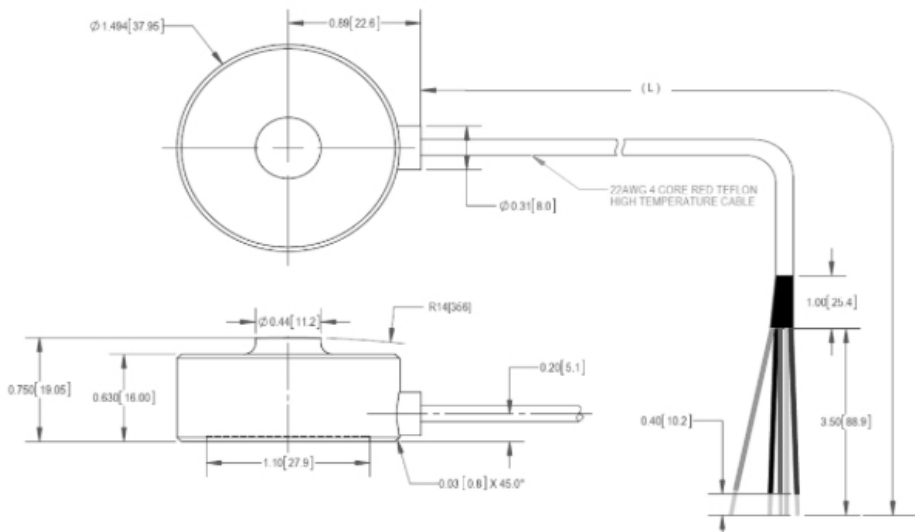

SPECIFICATIONS

Model	SBL	
Capacity	15klb	
Full Scale Output (FS)	mV/V	2.0±5%
Combined Error	%FS	<±1
Non-repeatability	%FS	<±0.5
Creep @30min	%FS	<±0.06
Zero Balance	%FS	<±5
Temperature Effect		
Output	%FS/10°C	<±0.18
Zero	%FS/10°C	<±0.36
Temperature Range		
Compensated	°C	-10 ~ +82
Operating	°C	-20 ~ +99
Terminal Resistance		
Input	Ω	386±30
Output	Ω	350±5
Excitation Voltage	VDC	5...15
Insulation Resistance	M Ω	>5000
Safe Overload Limit	%FS	150
Ultimate Load	%FS	200
Cable Length (L)	ft	40
Seal Type	IP67	
Element Material	Stainless Steel	

WIRING

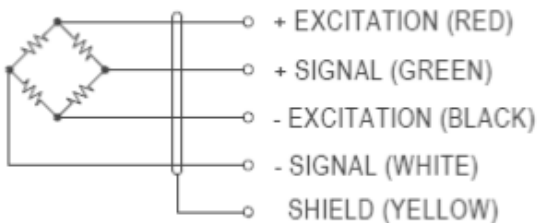

PART NUMBER

8040-000-00