

The 3i digital force/torque indicator is designed to work with a wide range of remote force and torque sensors. With exclusive plug & test technology, all calibration and configuration data are saved within the sensor's smart connector, not the indicator, allowing for true interchangeability.



FEATURES

- Interchangeable force and torque sensors through plug & test technology
- High speed 2,000Hz sampling rate
- USB data output
- Ultra compact size
- Large backlit graphic display
- Programmable set points with pass/fail indicators
- Live load bar graph with set point markers
- Peak readings and set point always displayed
- Configurable audio alarms and key tones
- 4 selectable units of measurement
- Mesur lite data collection software included



Plug & Test Technology

The plug & test connector locks into the receptacle in the indicator when fully inserted. Dual buttons on the indicator housing release the connector for easy removal. Gold plated spring contacts ensure long lasting and reliable connection.

APPLICATIONS

- Automotive Industry
- Manufacturing
- Assembly
- Quality control

DIMENSIONS

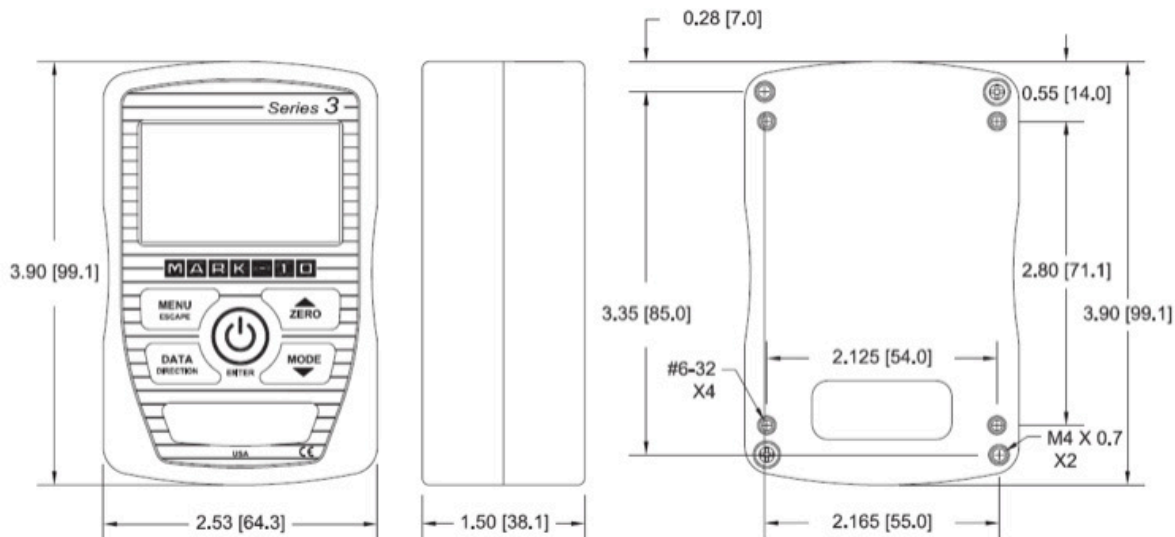

SPECIFICATIONS

Model	3i
Accuracy	±0.2% of full scale + sensor
Sampling Rate	2000 Hz, pulse response of 1/1000 sec. minimum
Power	AC or rechargeable battery. Multi-step low battery indicator is displayed gauge shuts off automatically when power is too low
Battery Life	Backlight on/off: up to 7/24 hours of continuous use
USB Output	By pressing DATA key only. Configurable up to 115,200 baud
Configurable settings	Digital filters, USB outputs, automatic shut off, default settings, key tones, audio alarms, calibration
Weight	0.7lb (0.33 kg)
Included Item	Carrying case, universal voltage AC adapter, battery, quick-start guide, USB cable, resource CD (USB driver, MESUR lite software, MESUR gauge DEMO software, and user's guide), and certificate of conformance
Warranty	3 years (see individual statement for further details)

PART NUMBER

Model	Description
M3I	Advanced Force/Torque Indicator, 110V
M3IE	Advanced Force/Torque Indicator, 220V, European Plug
M3IU	Advanced Force/Torque Indicator, 220V, UK Plug
M3IA	Advanced Force/Torque Indicator, 220V, Australian Plug
AC1008	Tabletop mounting kit for 3i/5i